

Development and Optimisation of a Two-Stage SiPM-Based Compton Camera

Shanyn Hart, Postdoctoral Researcher at iThemba LABS

ANSTT 2026

Compton Camera Principle

Scatterer and Absorber Layers:

MacroPixel LB-14x25c-SiPM-T LaBr₃:Ce detector assemblies in 4 × 1 arrays.

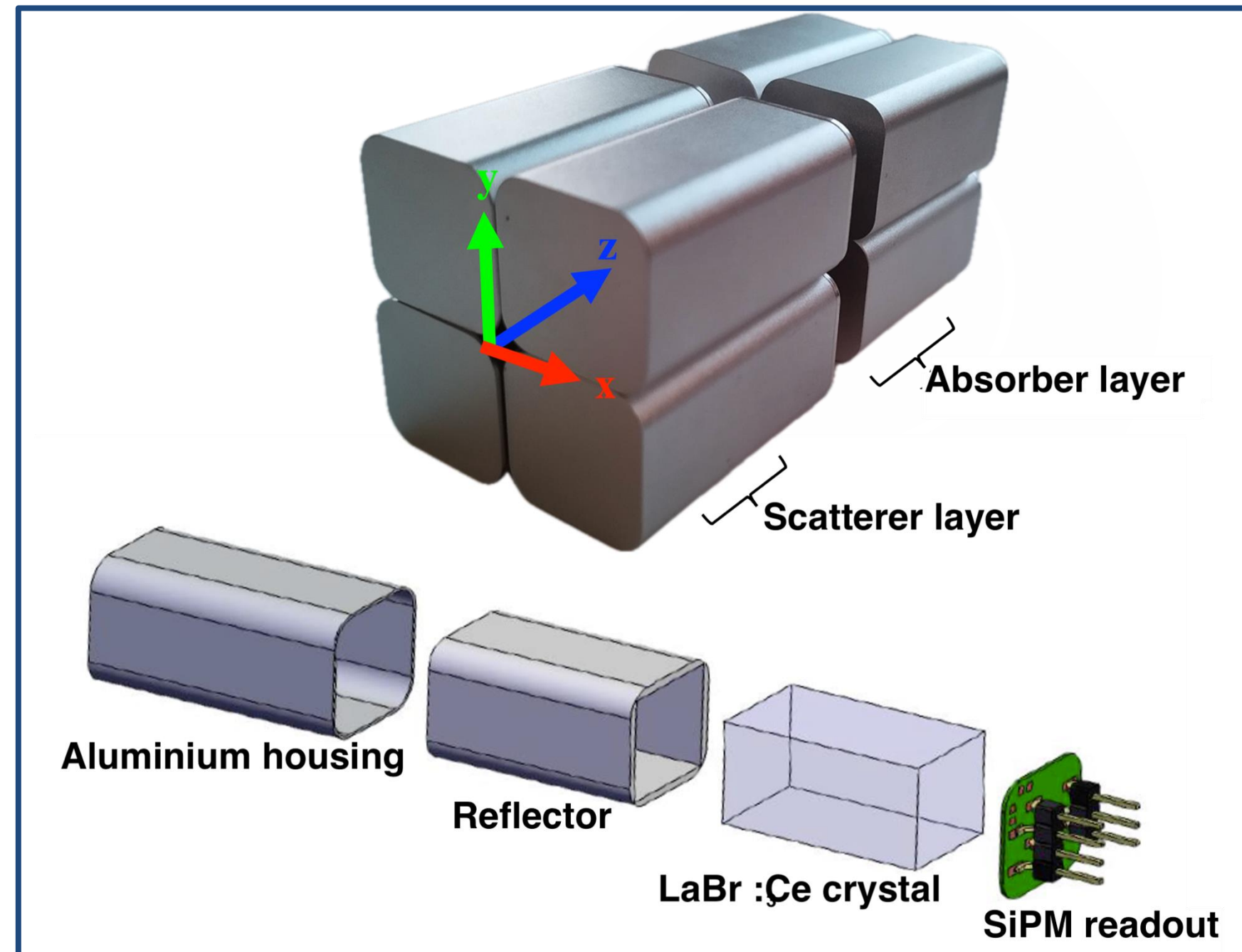
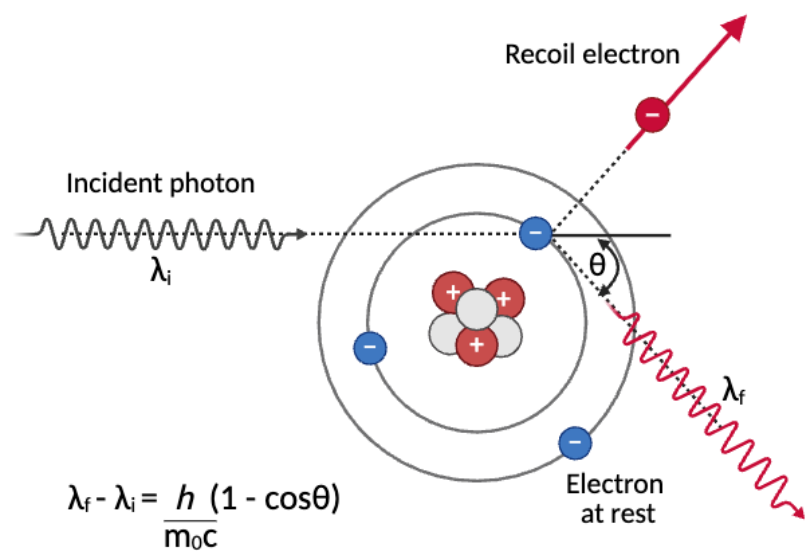
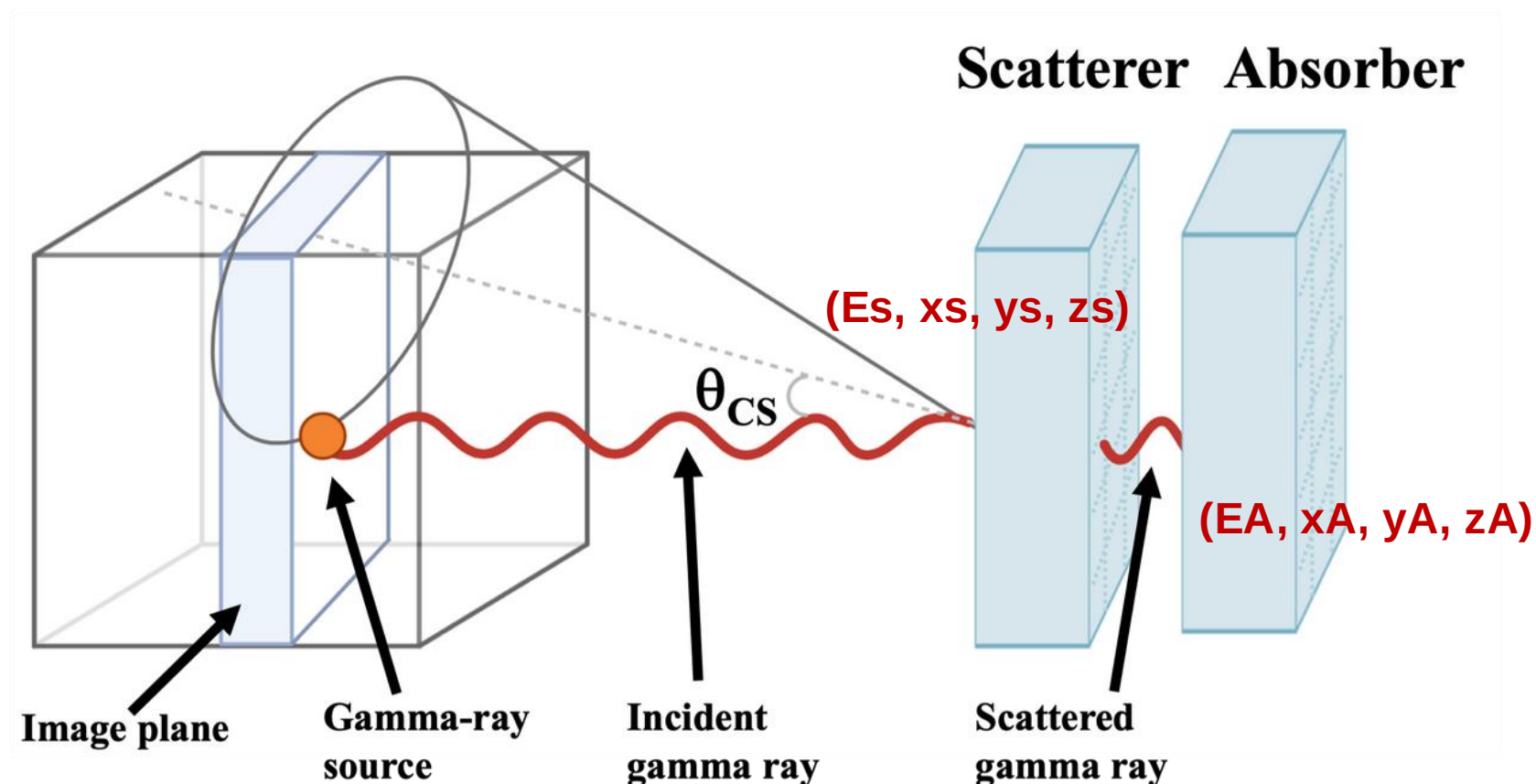

Compton Camera Geometries Investigated

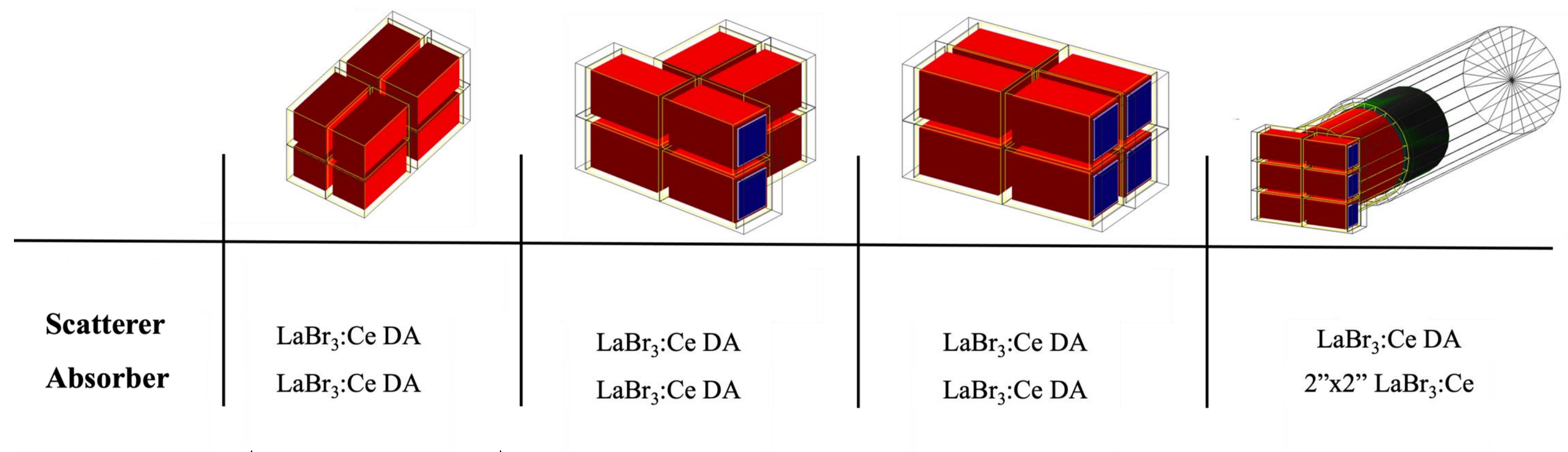

I will discuss this design.

CC Detector Characterisation

Compton Camera of $\text{LaBr}_3:\text{Ce}$ detectors ($14 \times 14 \times 25.4 \text{ mm}^3$) coupled to a **2x2 MicroFJ-60035-TSV SiPM** array and **TMP451** temperature sensor packed in an aluminium canister. Manufactured by **CapeScint** (MA,USA).

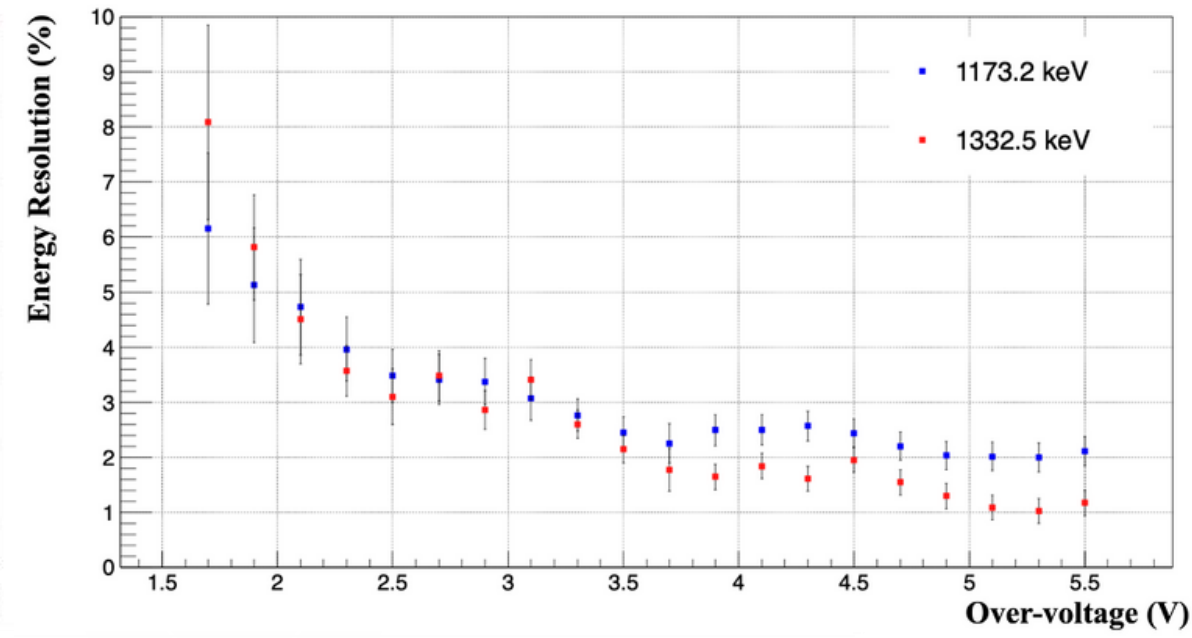
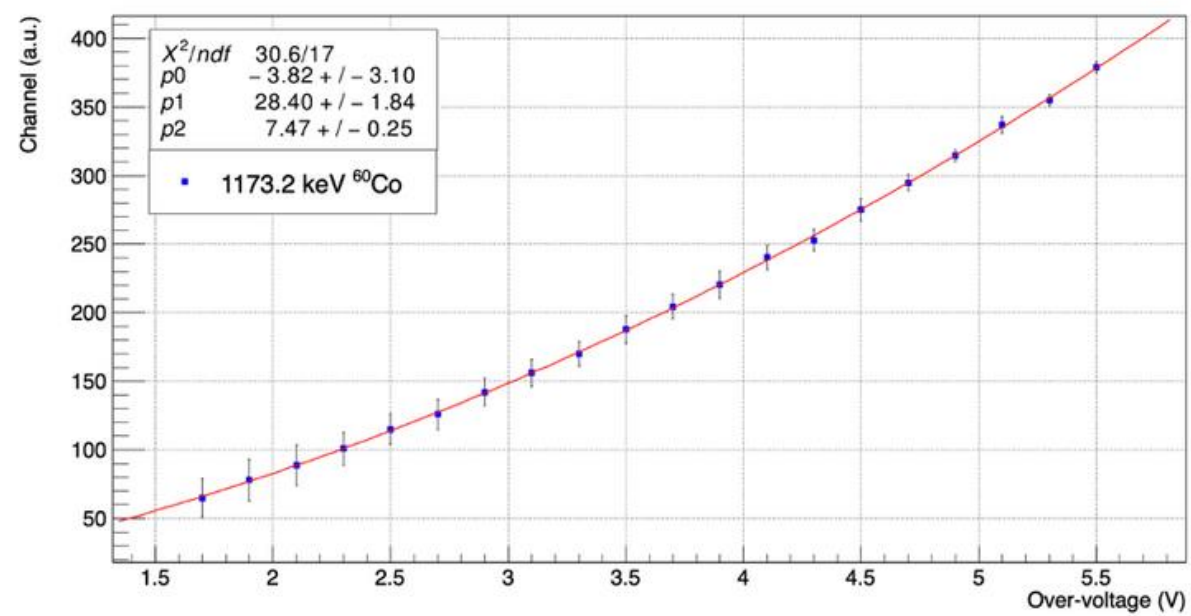
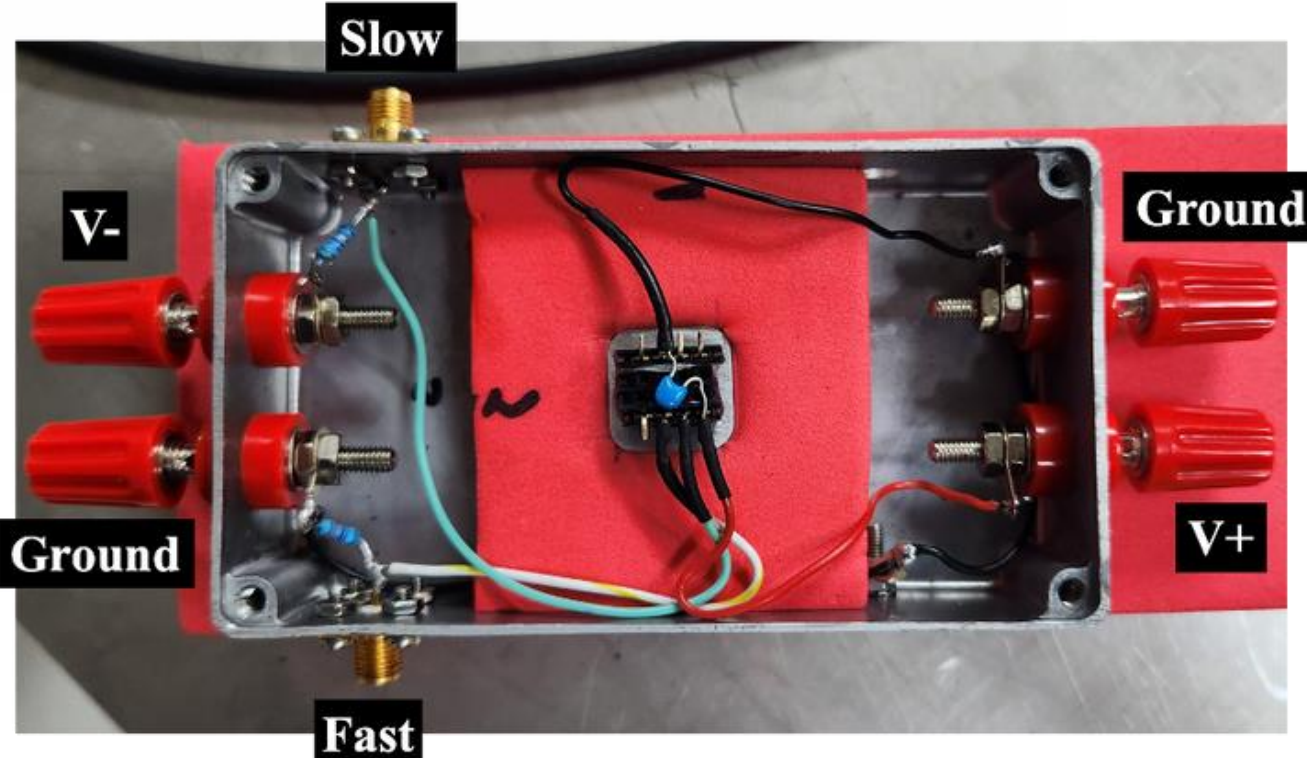
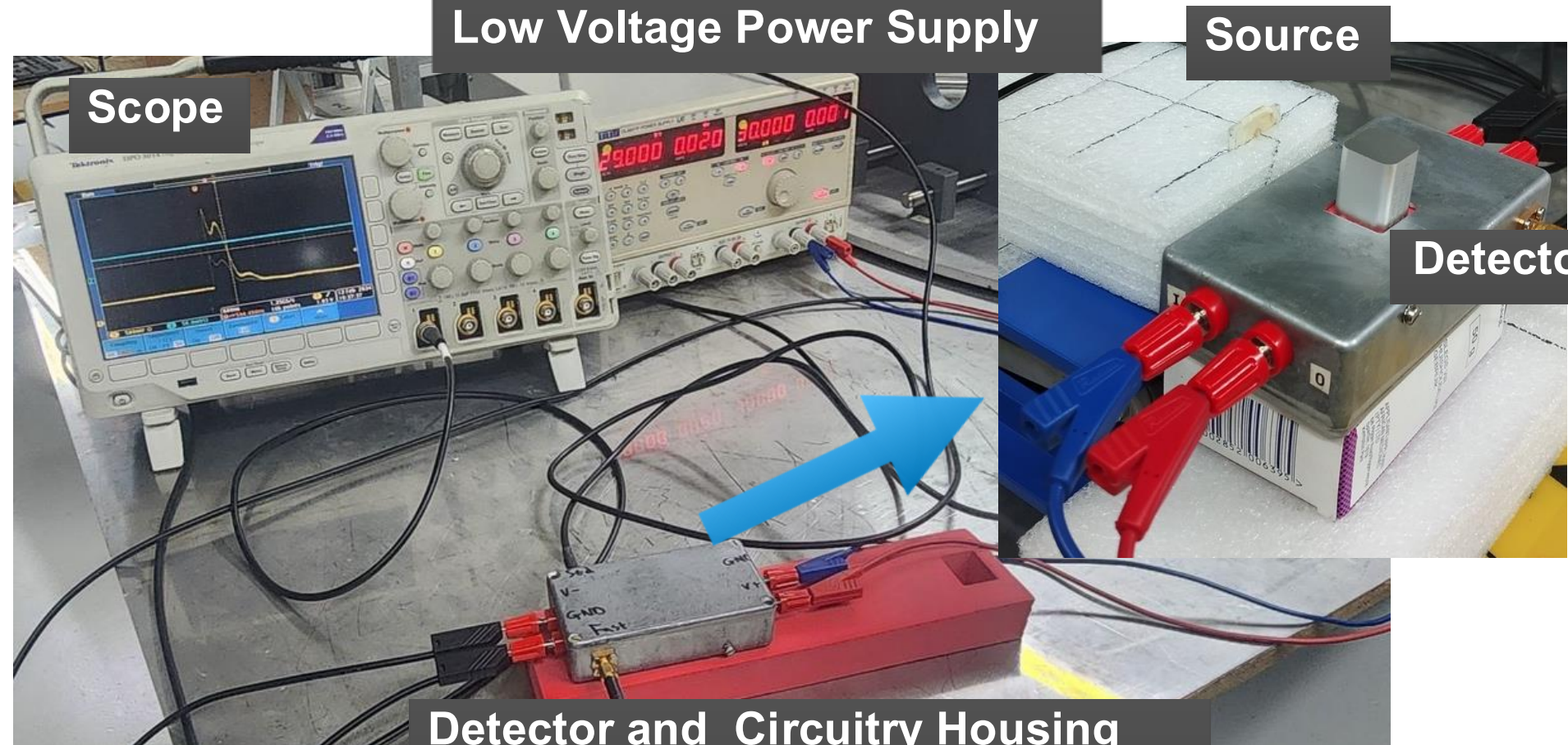
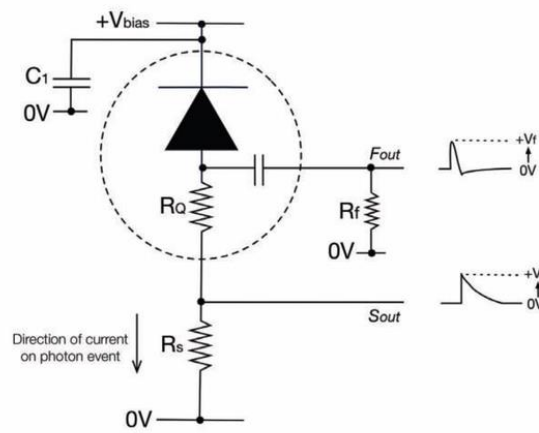
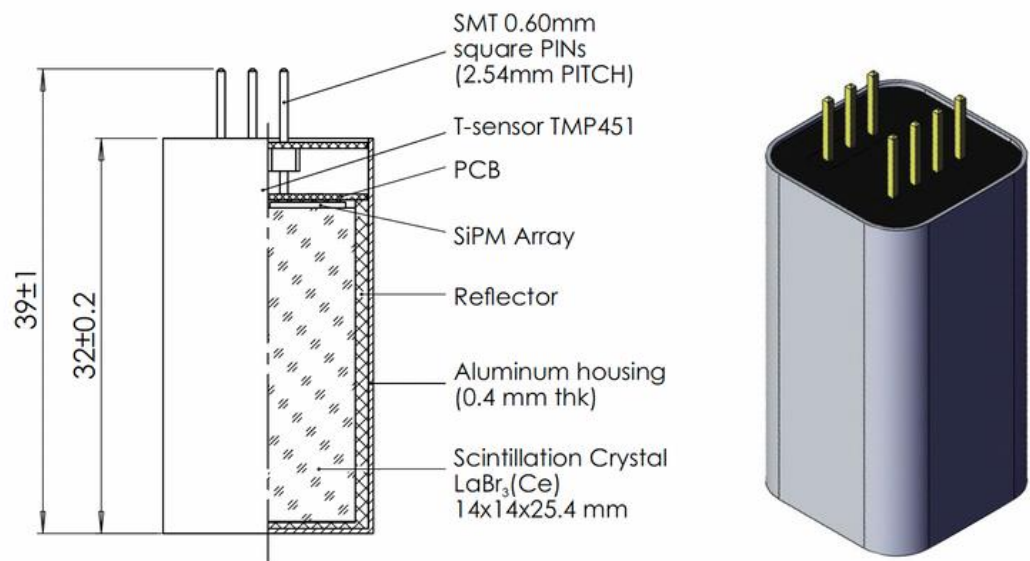

Operational voltage chosen to be 30 V (5.3 V overvoltage)

Validation of CC Detector Simulation



Geant 4

TOPAS MC Inc is a proud user of the Geant4 Simulation Toolkit

LaBr₃:Ce-SiPM

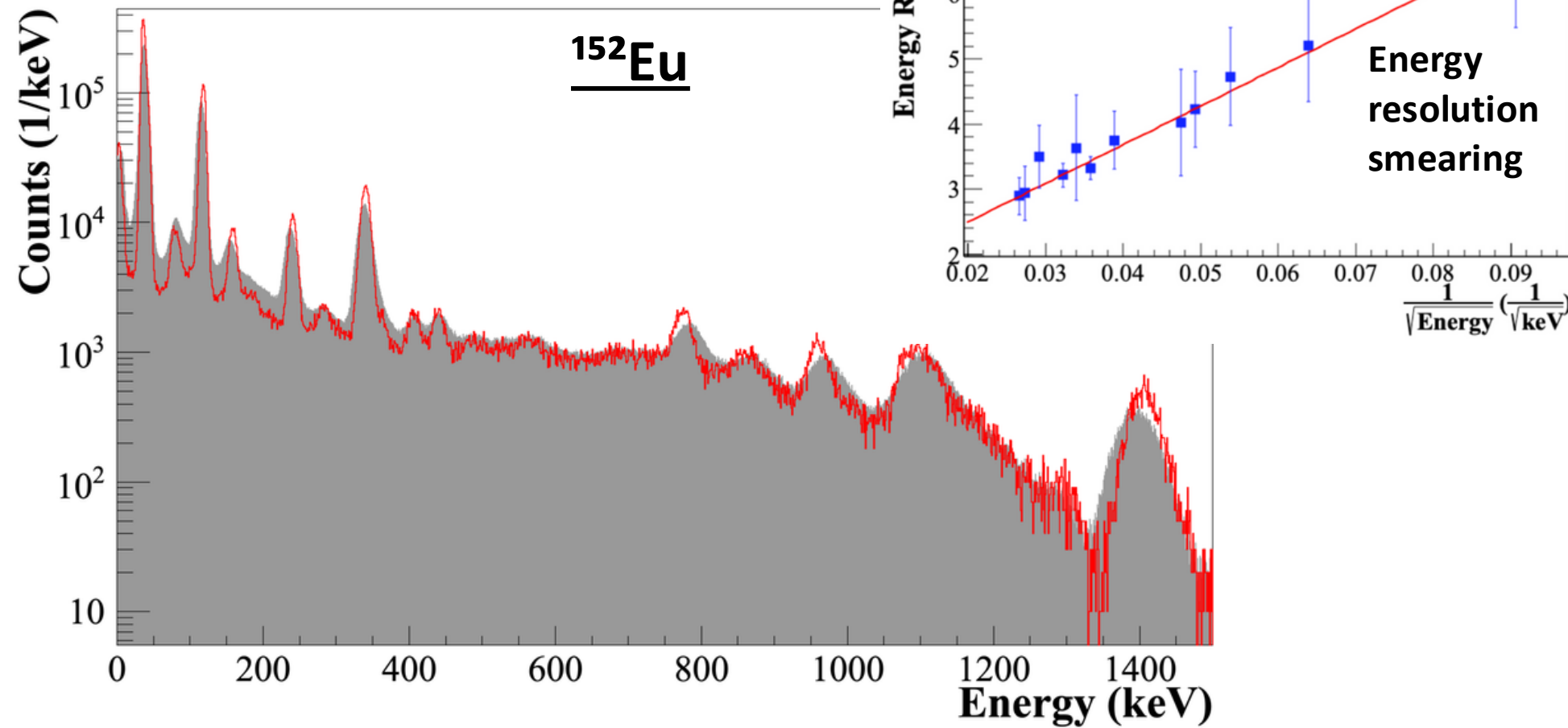

High efficiency for Compton scattering at low energies. Good candidate for addback.

Distance (mm)	344.28 keV			968.08 keV		
	$\epsilon_{EXP,FEPE}$ (%)	$\epsilon_{SIMU,FEPE}$ (%)	Agreement (σ)	$\epsilon_{EXP,FEPE}$ (%)	$\epsilon_{SIMU,FEPE}$ (%)	Agreement (σ)
10.0	1.38(19)	1.50(10)	0.56	0.223(63)	0.196(13)	0.42
30.0	0.332(142)	0.449(90)	0.70	0.123(31)	0.078(21)	1.20
50.0	0.141(16)	0.204(53)	1.14	0.042(39)	0.039(12)	0.074
100.0	0.043(7)	0.044(9)	0.088	0.009(17)	0.009(10)	0

Table Comparison of experimental and simulation for the LaBr₃:Ce DA absolute full-energy peak efficiencies and associated uncertainties for gamma-ray energies 344.28 keV and 968.08 keV at various source-to-detector distances.

Triangular Optimisation of slow signal (Flat top = 0)

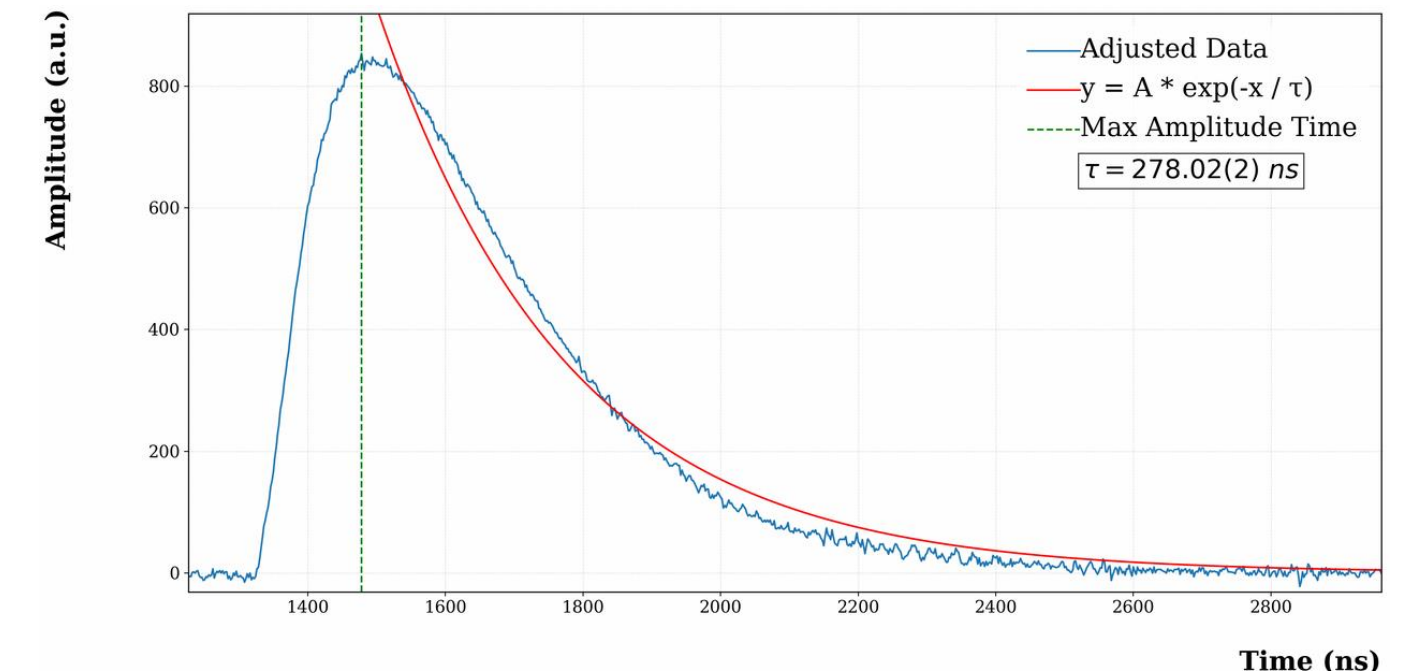

3.41(20) % @ 662 keV

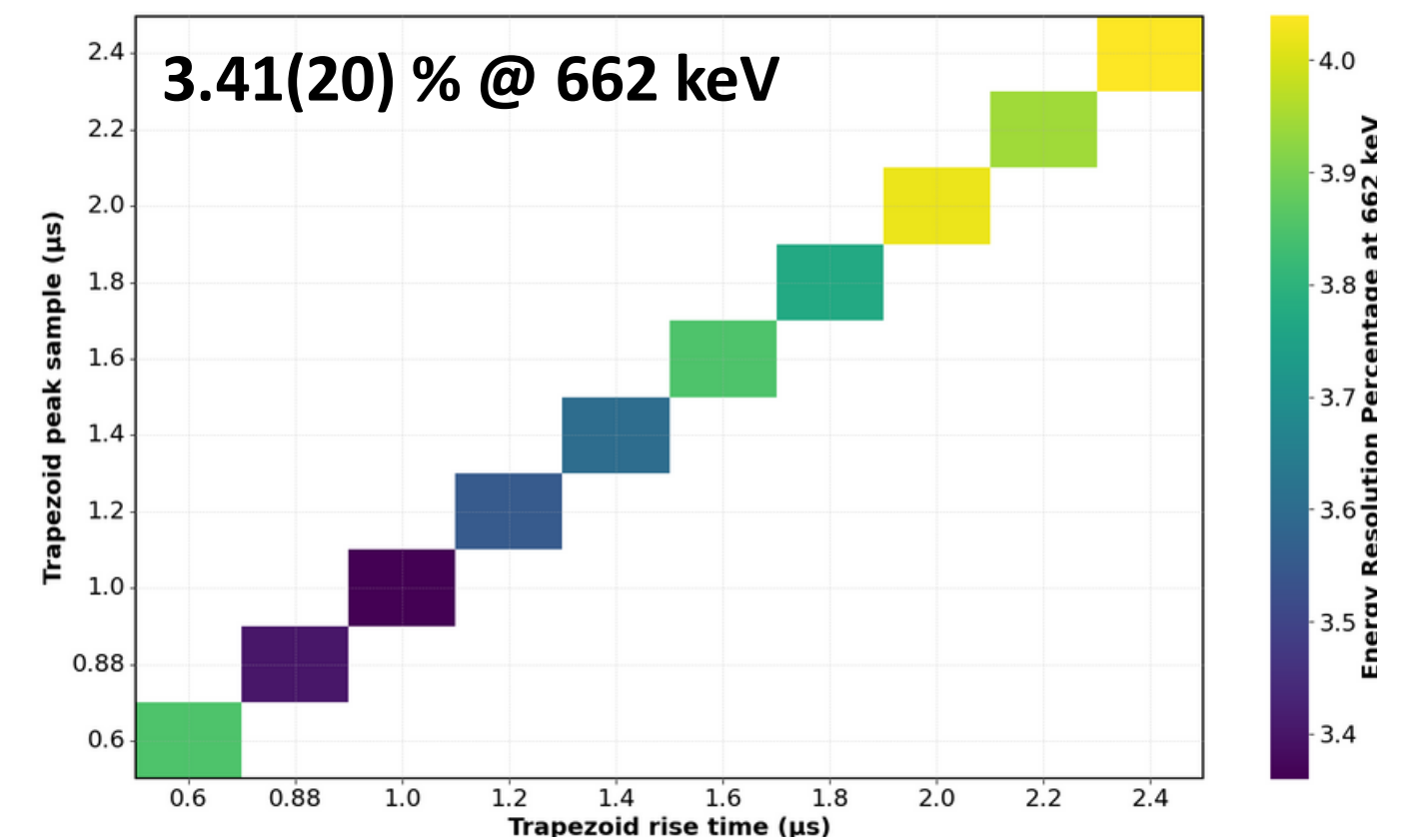

Results of CC Simulation

Measurements performed with ¹³⁷Cs Source at (0,0,10) mm from scatterer face

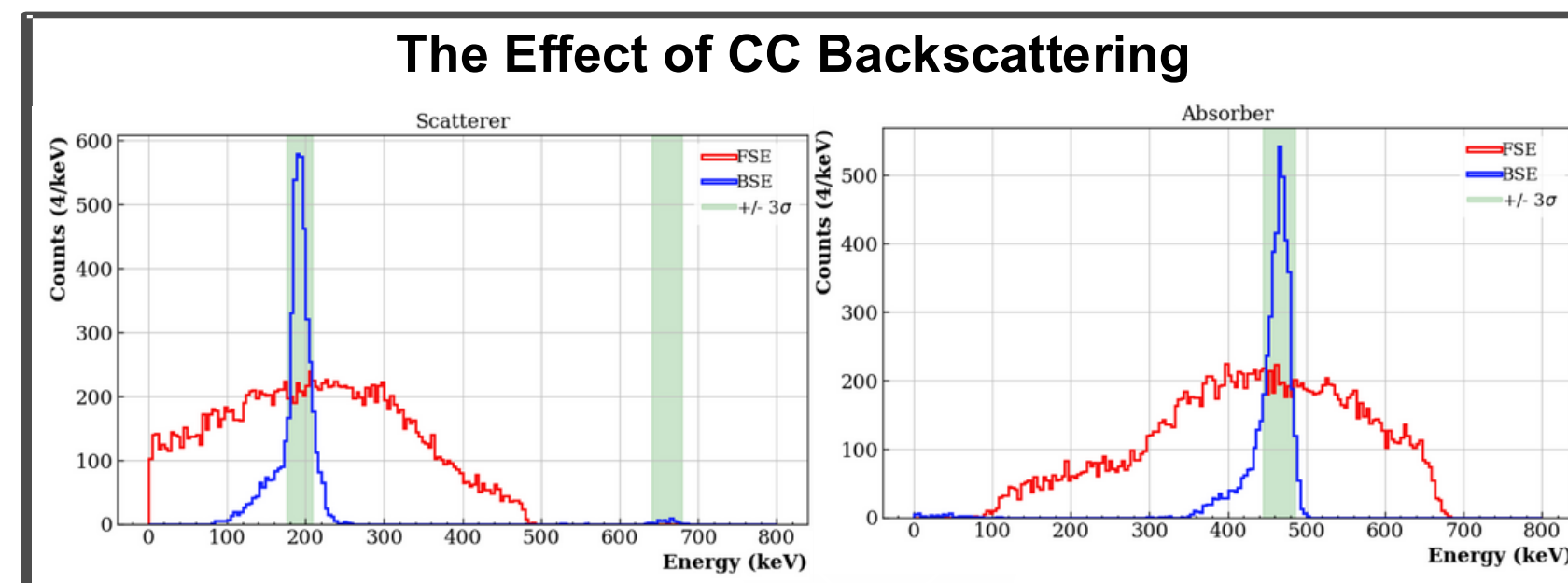
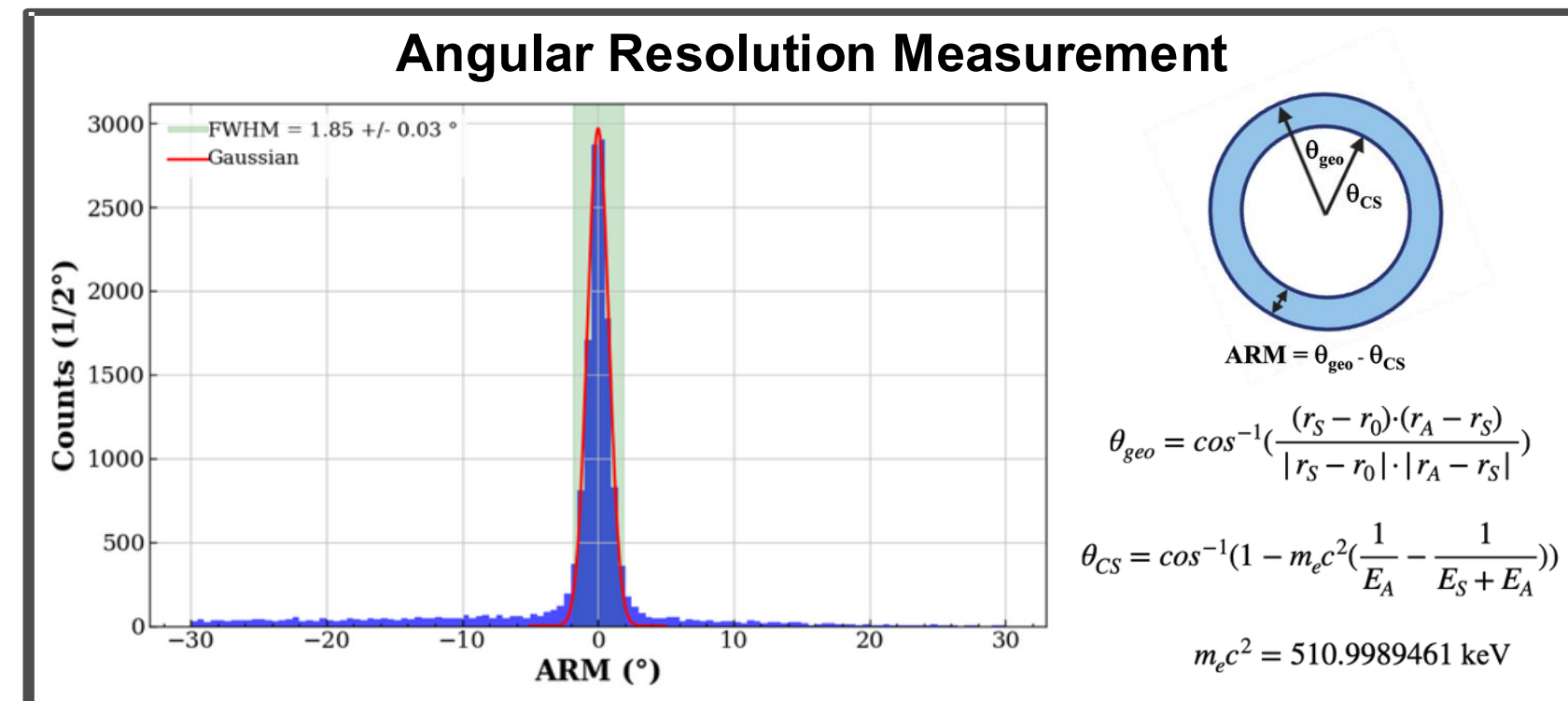
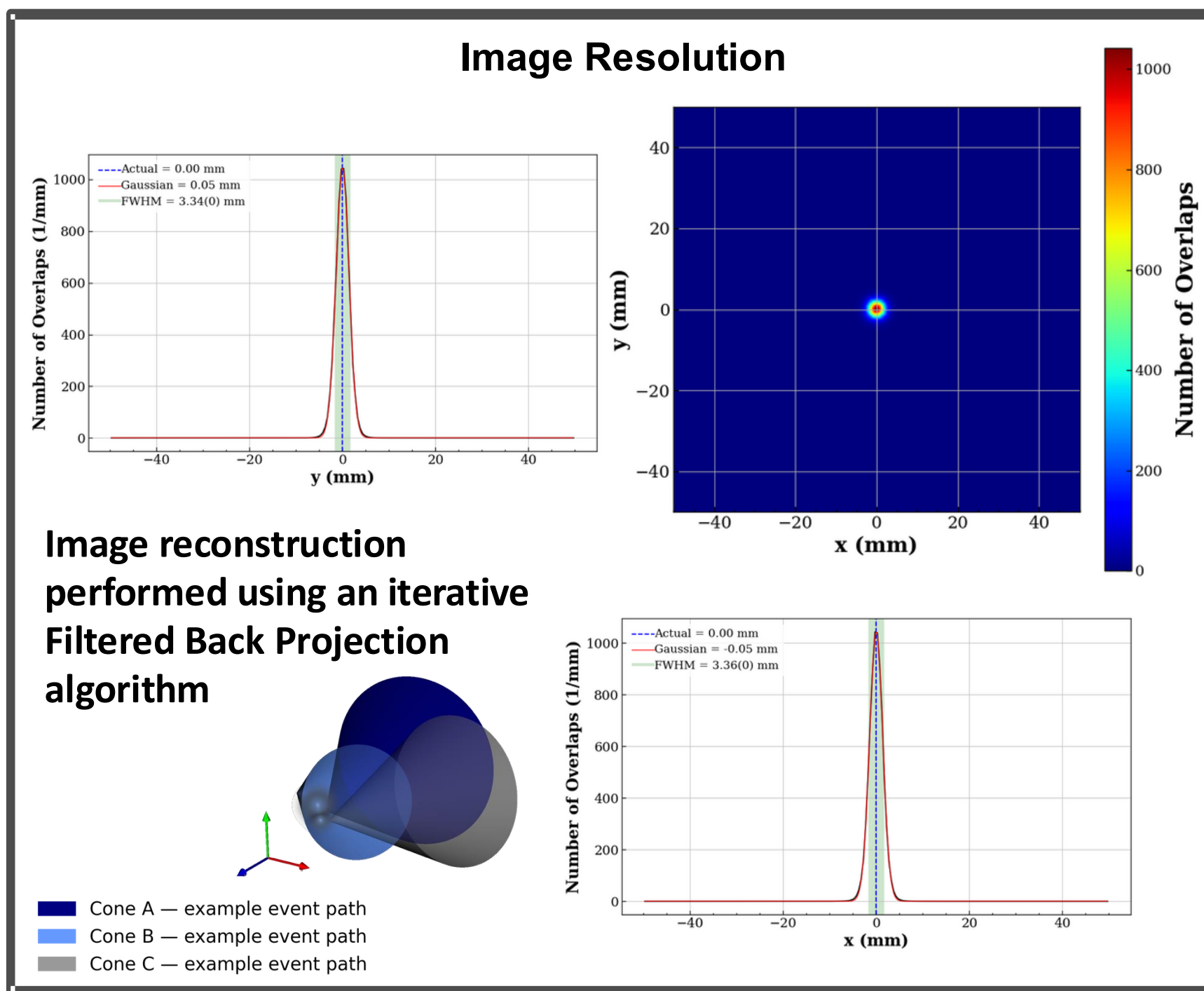
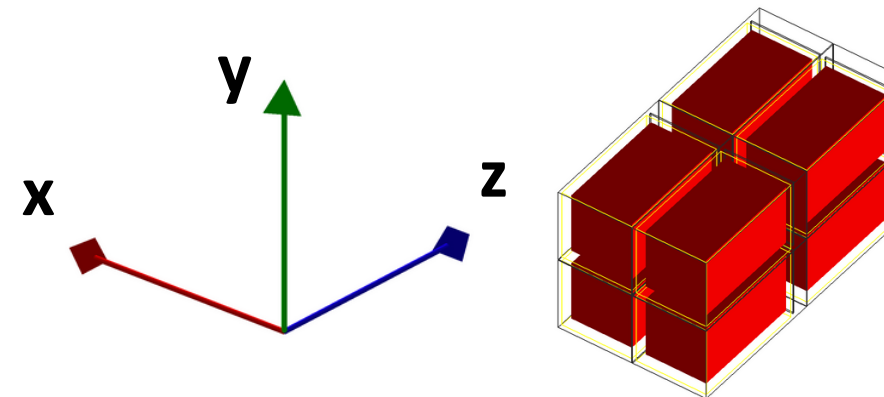

DA Fast Timing Performance

Calculated by gating on the ^{60}Co prompt-gamma decays. The time interval between the **1173 keV** and **1332 keV** emissions is **<0.9 ps**, effectively instantaneous compared to detector resolution.

Measurements performed using the **14-bit XIA PIXIE-16 500 MHz** data acquisition system, exploiting the use of the **digital CFD** for fast timing.

Two 2" x 2" LaBr₃:Ce detectors

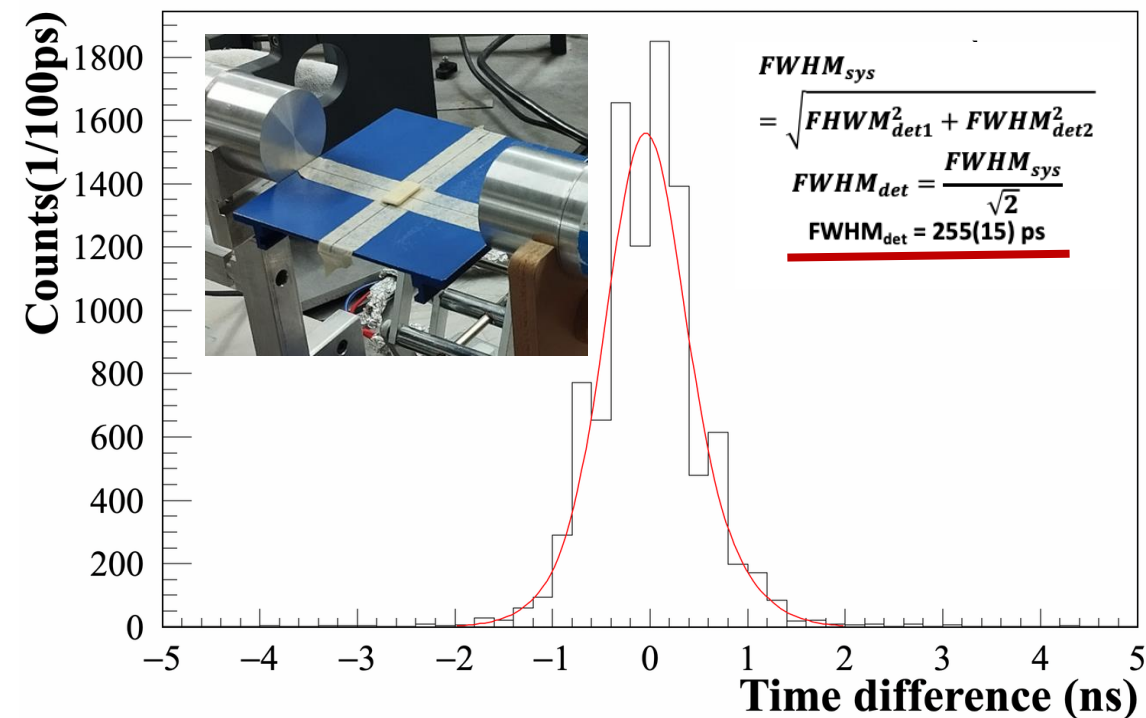

2" x 2" and DA LaBr₃:Ce detectors

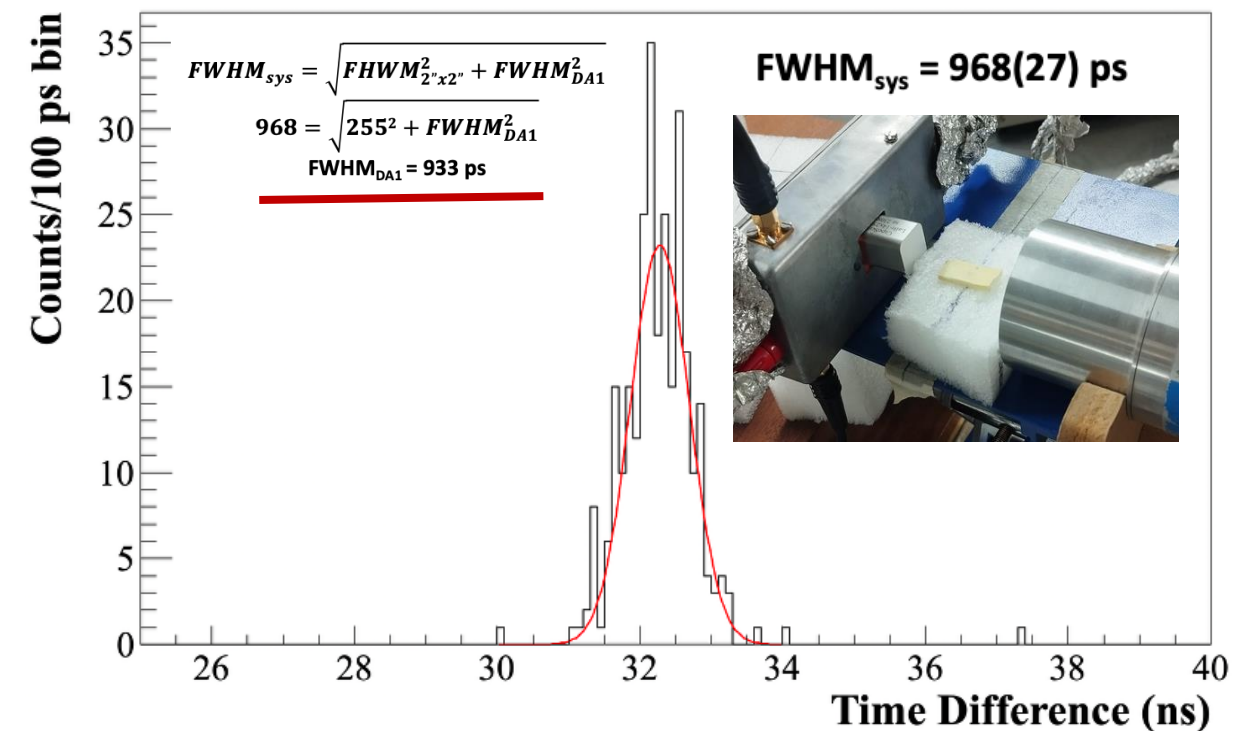

Two LaBr₃:Ce DAs

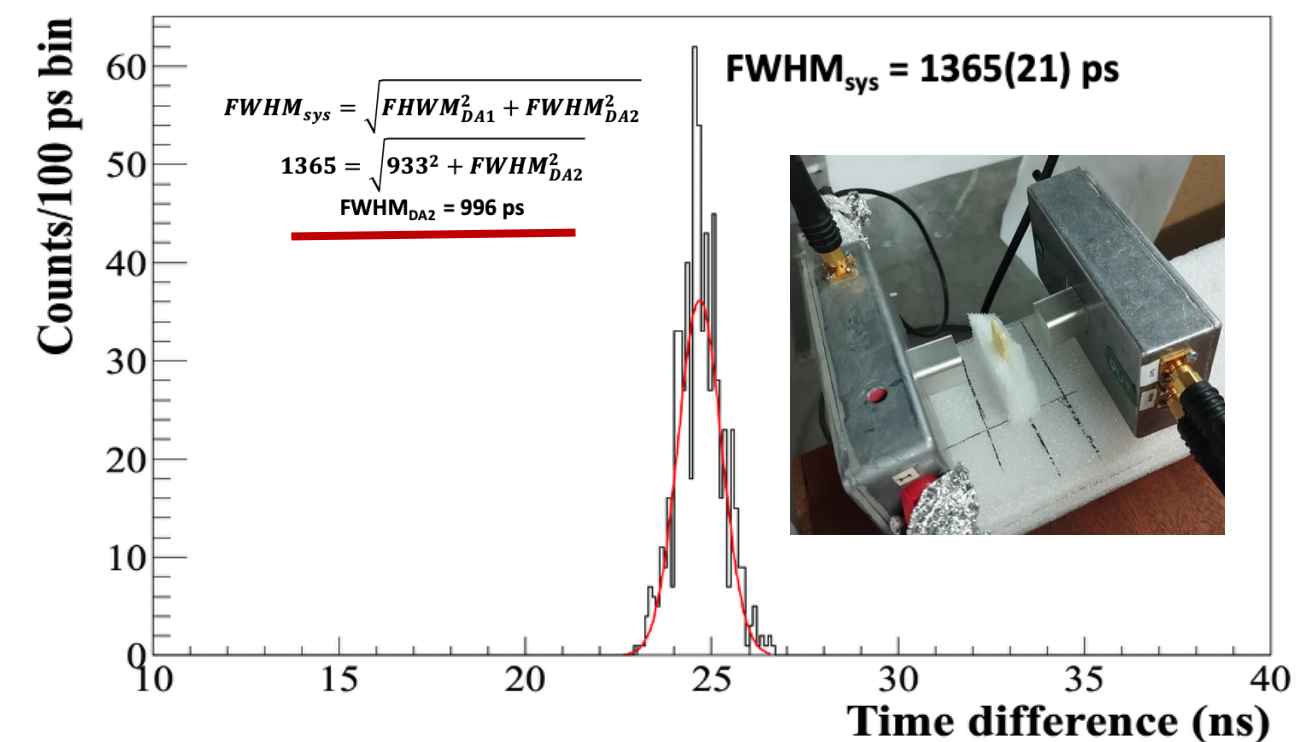

Postdoctoral Research



Current & Upcoming Work

Position-sensitive detection in LaBr₃:Ce scintillators

Improving spatial resolution using **Broadcom AFBR-S4N44P164M 4×4 SiPM arrays**

Custom development boards currently in production

Enhanced Geant4 simulations

Realistic performance modelling for detector optimisation

Drone-based deployment of Compton Cameras

Environmental monitoring and mapping applications

In-beam proton testing

Evaluation with **70 MeV and 200 MeV proton beams** for medical imaging

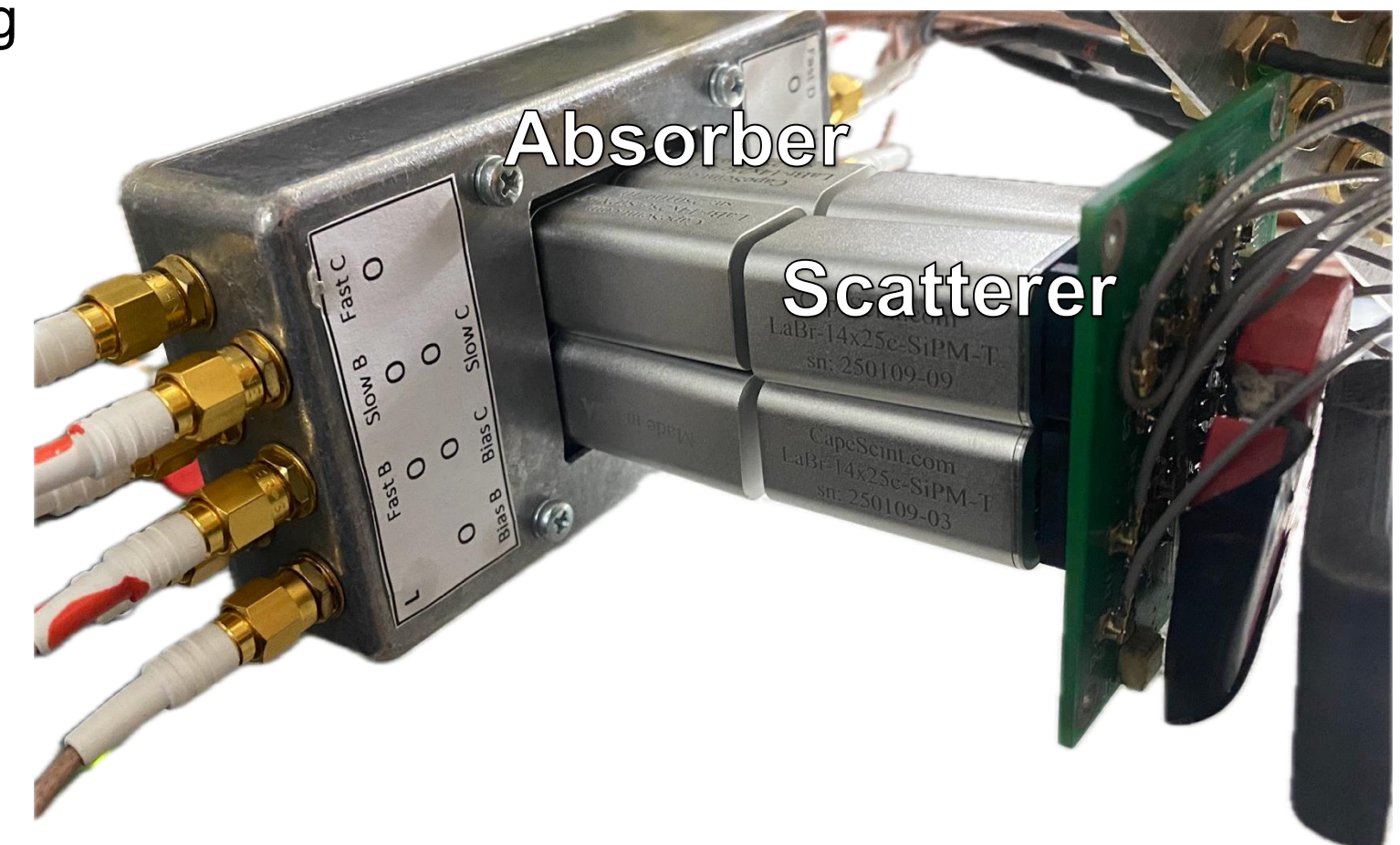
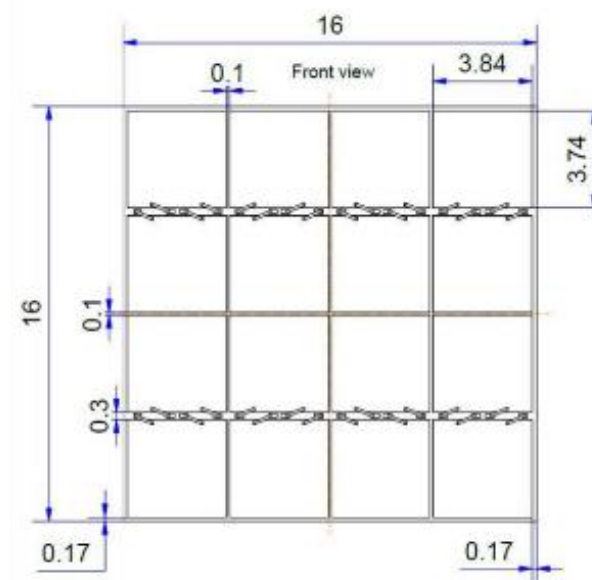
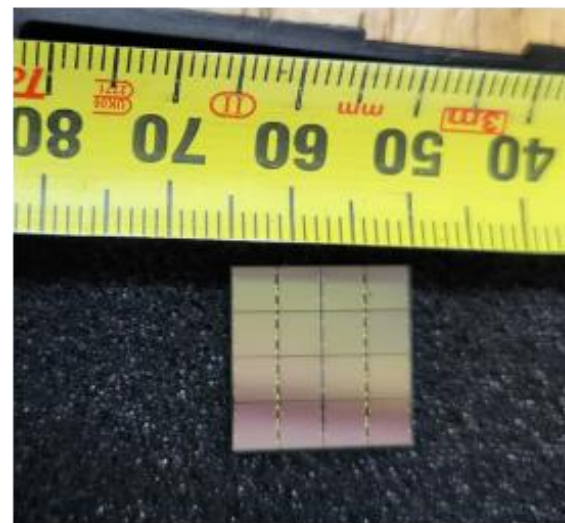
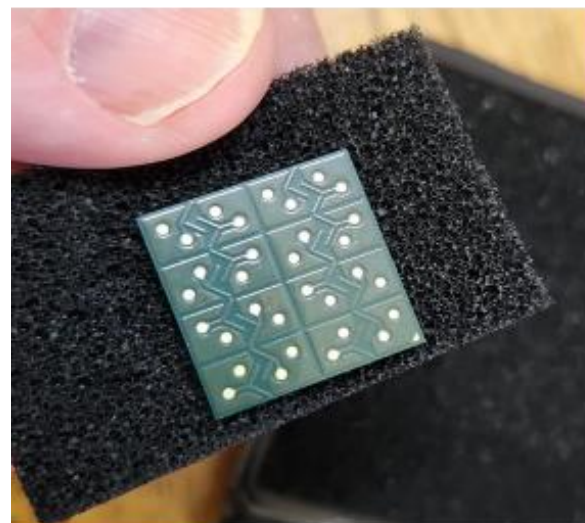
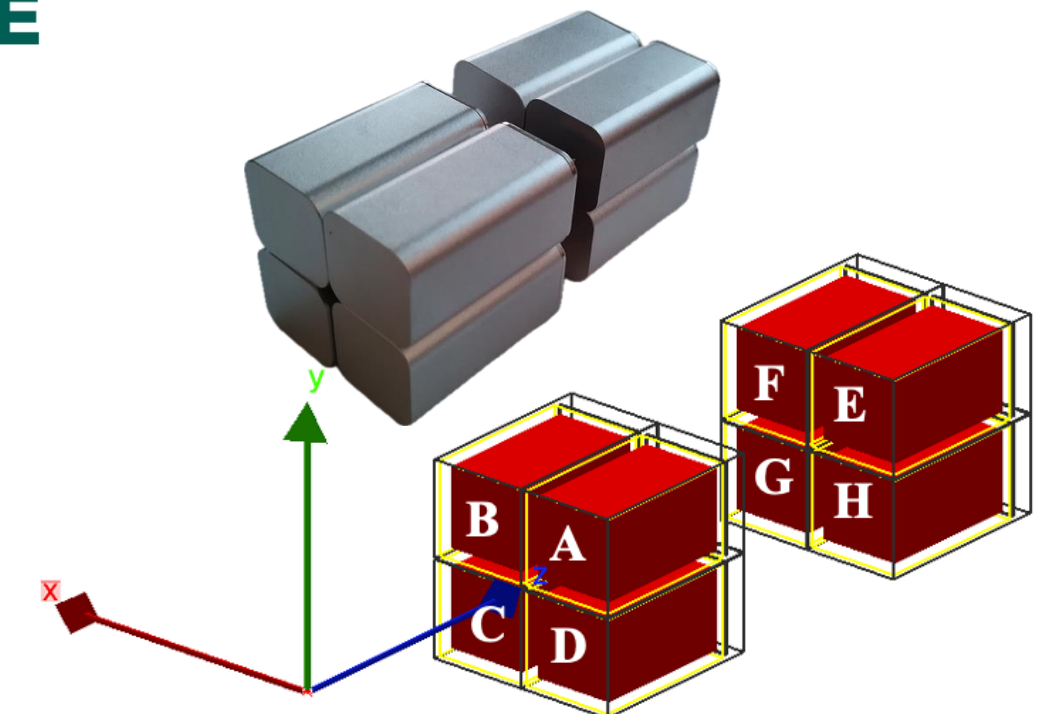

The **P**ortable **A**frican **N**eutron-**G**amma **L**aboratory for **I**nnovative **N**uclear **S**cience

Milestones

Reduce footprint of the Mobile Radiation Detection Unit

Adopt next-generation detectors

→ LaBr₃, Srl₂, CLYC (Cs₂LiYCl₆)

Enable neutron sensitivity

→ Effective gamma–neutron discrimination

Transition from photomultipliers to SiPMs

→ Compact, low-power silicon avalanche photodiodes

Eliminate high-voltage requirements

→ Move to stable low-voltage operation

Characterise and deploy advanced measurement systems

Expand field testing

→ On-foot surveys and drone-based in-situ deployments

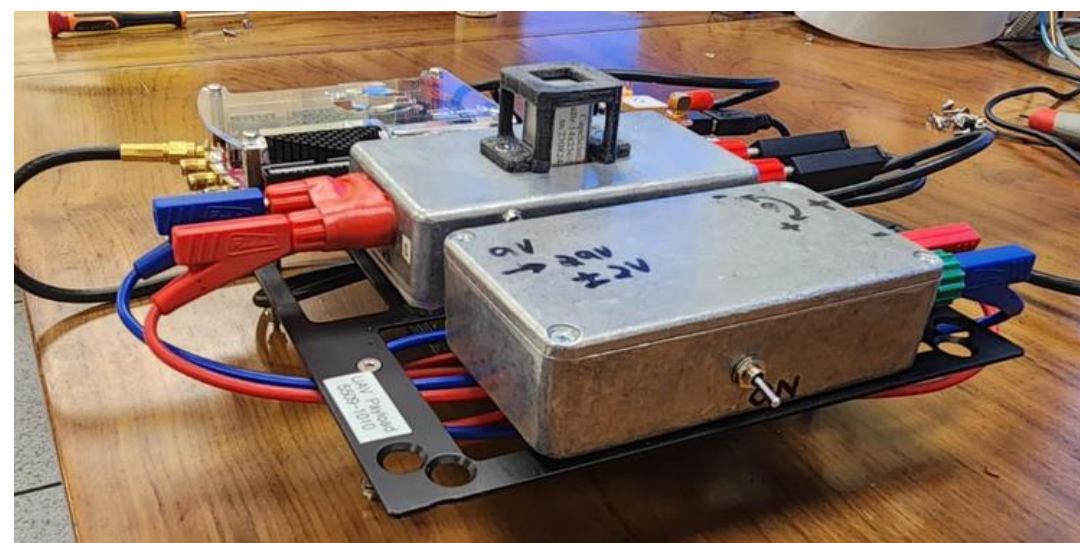

CLYC-6 for Thermal Neutron Detection

Measurements:

$^{241}\text{Am}/^9\text{Be}$ neutron source (6.9 GBq) and ^{60}Co gamma source

PIXIE-16 500 MHz DAQ

Elpasolite crystal $\text{Cs}_2\text{LiYCl}_6:\text{Ce}$ ($^6\text{Li} = 95\%$) detector **slow signal**.

$^6\text{Li} + n \rightarrow ^3\text{H} (2.73 \text{ MeV}) + \alpha (2.05 \text{ MeV})$ Q-value = 4.78 MeV, $\sigma = 940$ barns at

$E_n = 0.025 \text{ eV}$.

$^{35}\text{Cl} + n \rightarrow ^{35}\text{S} + p$

3.2 MeV thermal neutron peak observed due to quenching effects.

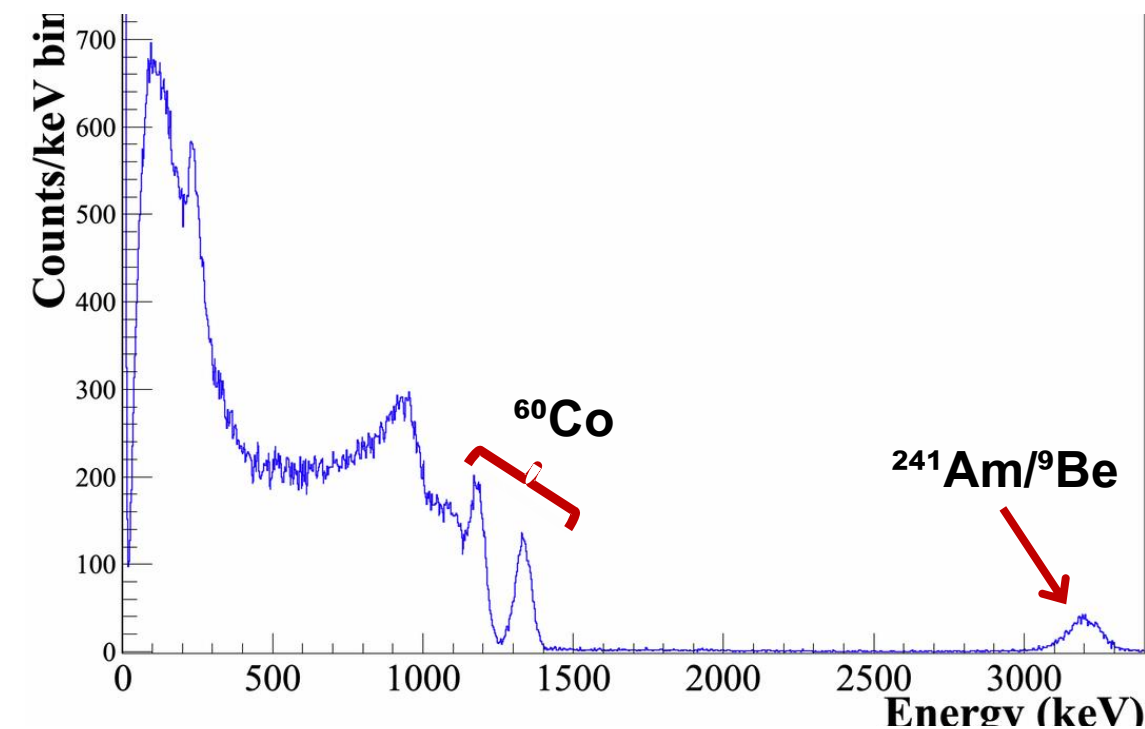

PSD is based on the difference in the scintillation decay response to gamma and neutrons

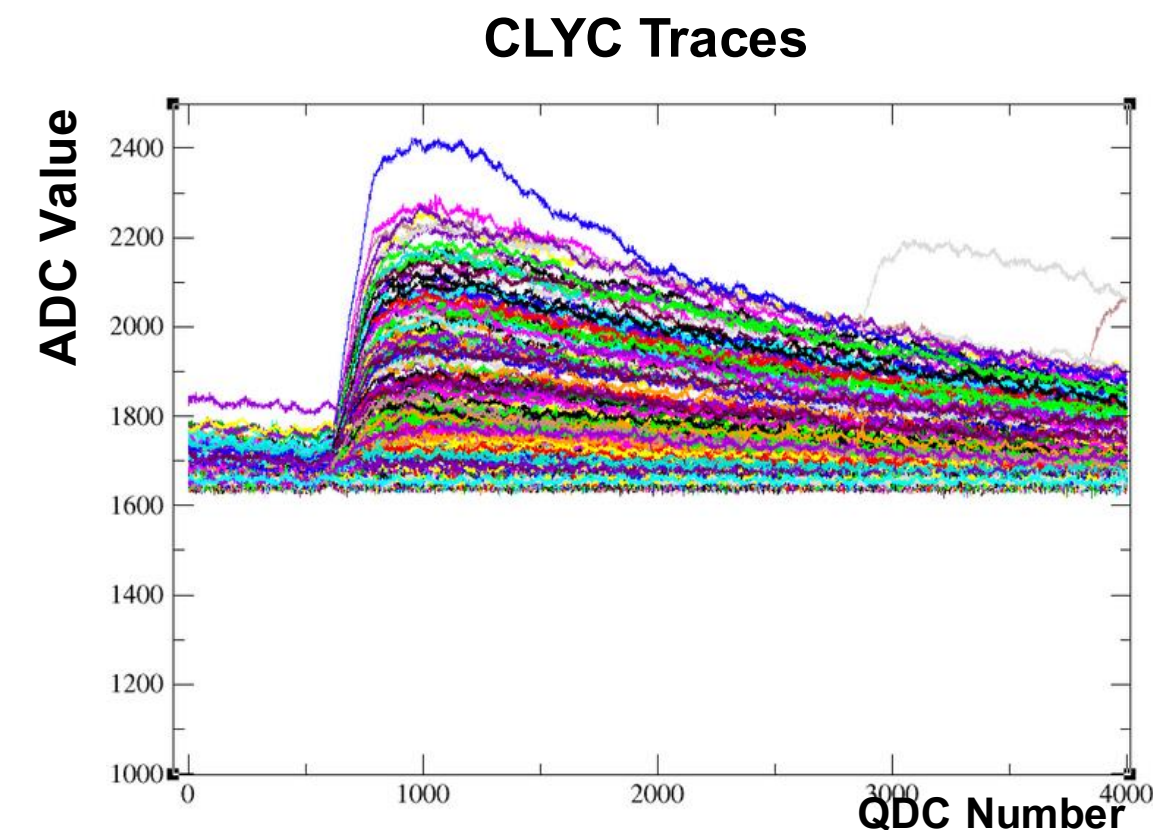
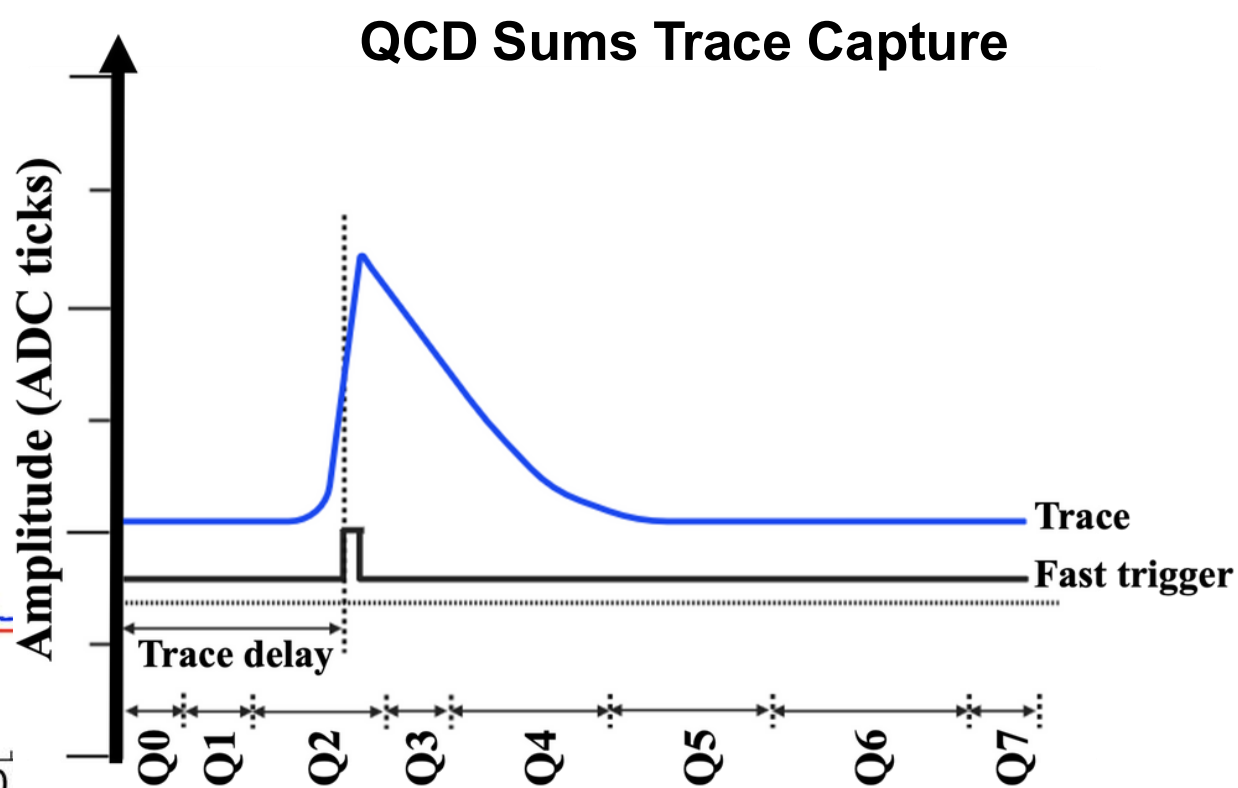
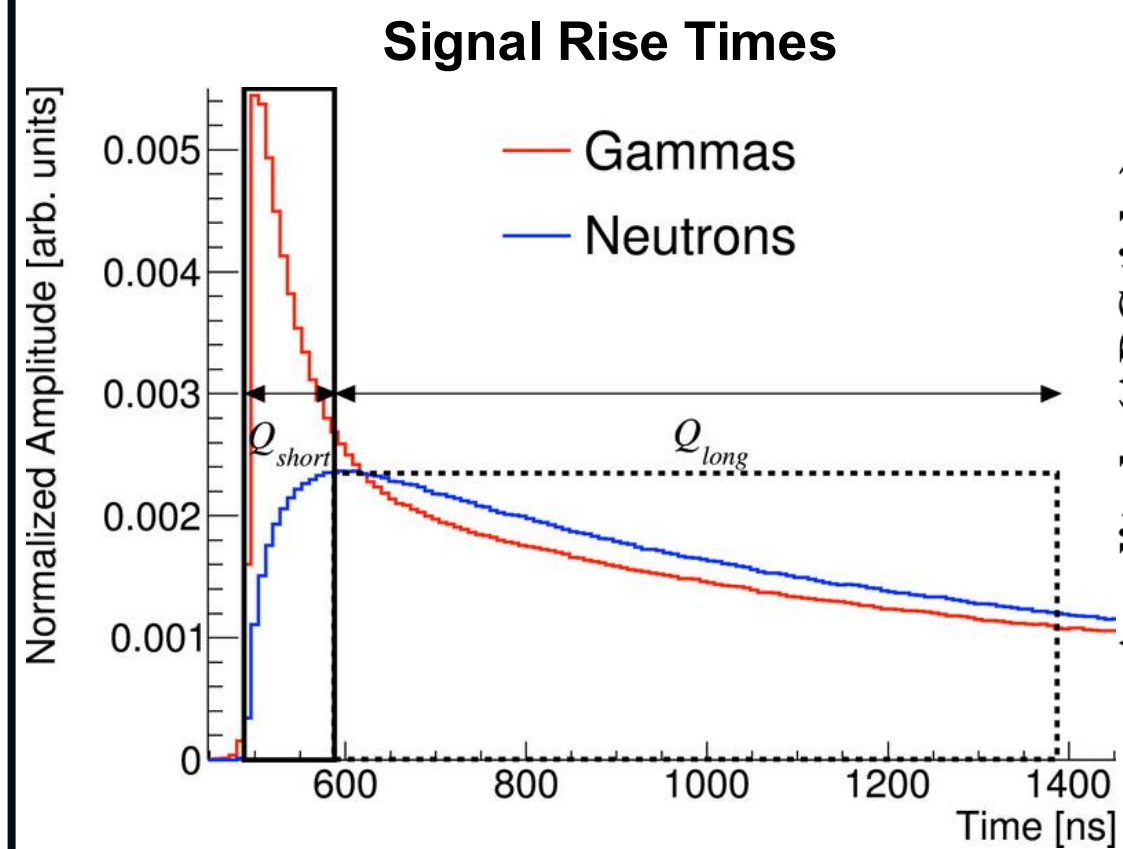

Another Application: CLYC-6 for Thermal Neutron Detection

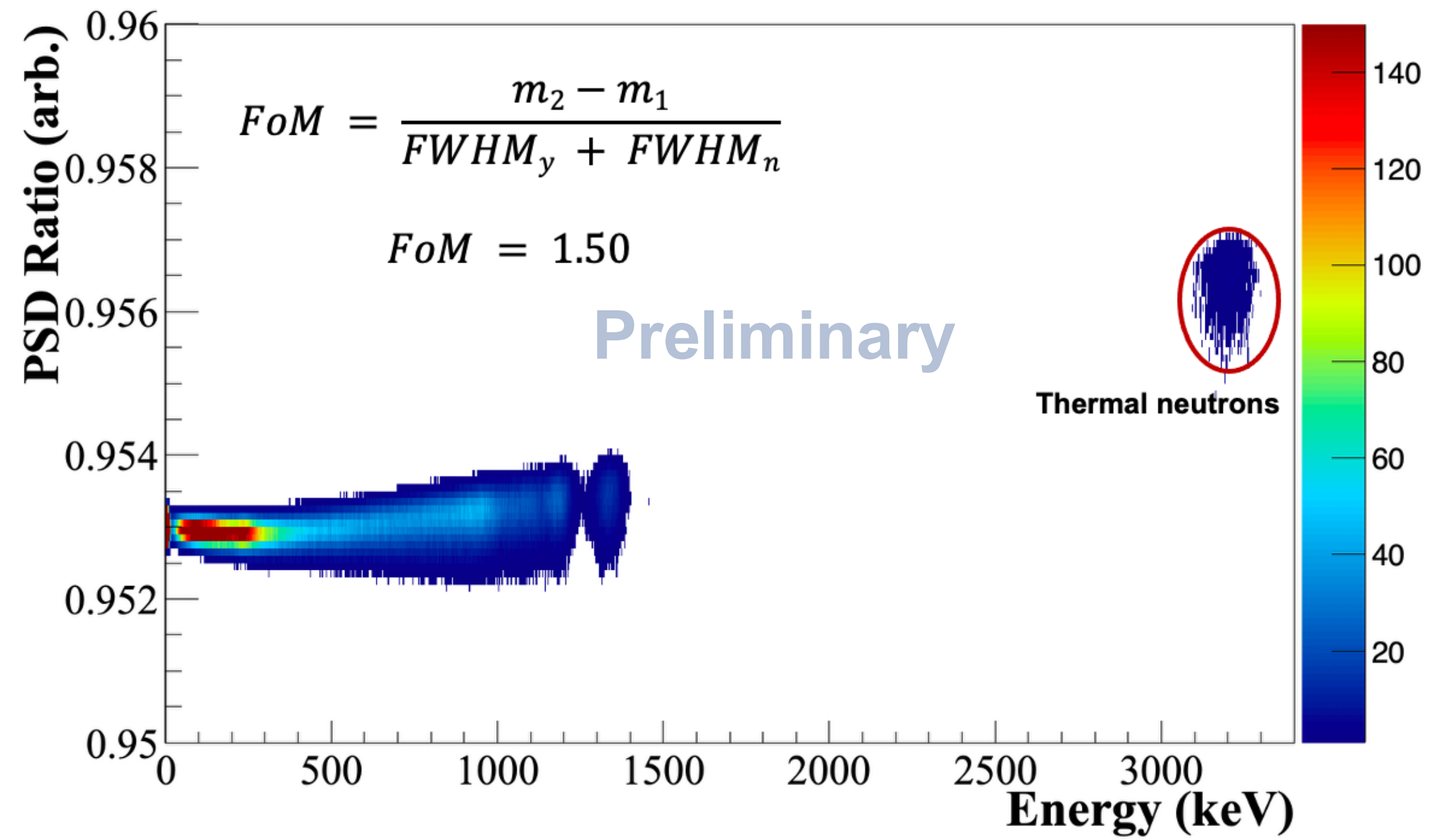
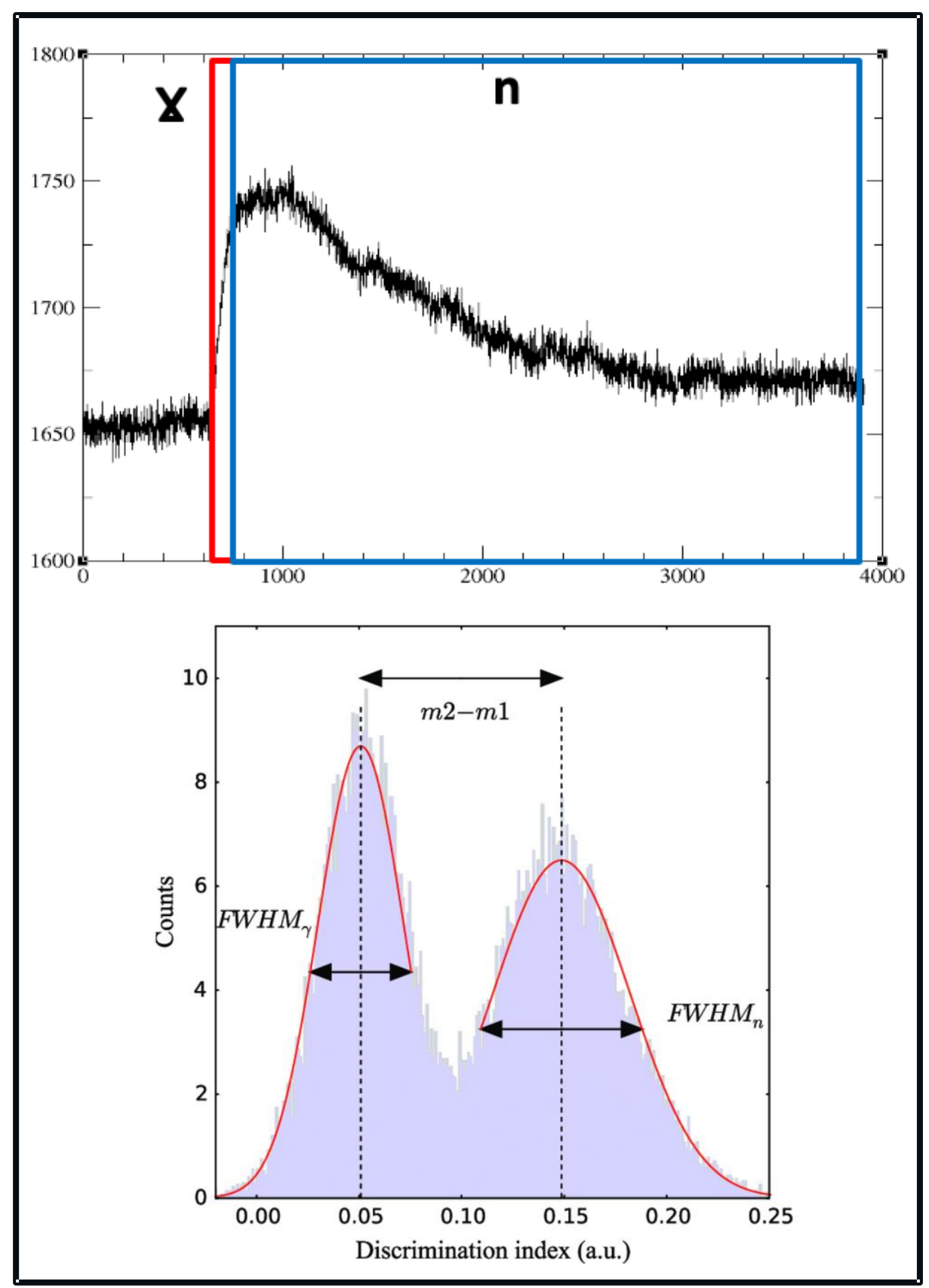



DASSIE Project

Digital Acquisition Signal System for Innovative Experimentation

Goal: Develop a **low-power, low-cost, lightweight, and scalable** streaming digitiser for real-time radiation detection.

Applications: Medical imaging, environmental monitoring, and security.

Key Features:

- Local **pulse shape analysis**, real-time **network streaming**, and time-stamped data storage.
- Compatible with **small-volume scintillator detectors**
- **Wireless user interface** for control and data access.

Hardware Specs:

Digitisation: 1 GHz, 14-bit ADC, ± 1 V range

Firmware Features:

- Digital Leading-Edge / CFD
- Moving Window Deconvolution (adaptive preferred)
- Pile-up detection
- 8 user-defined integration windows
- External trigger handling to reduce data rate



Science and
Technology
Facilities Council



iThemba
LABS
Laboratory for Accelerator
Based Sciences

Acknowledgements

Collaborators & Contributors

Dr. Pete Jones
Assoc. Prof. Luna Pellegrini
Prof. Steve Peterson
Mr. Christo van Tubergh
Dr. Philippos Papadakis
Mr. Moschos Kogimtzis
Dr. Carl Unsworth
Dr. Matthew Russell
Dr. Marc Labiche

Funding Support

National Research Foundation (NRF)
UKRI Science and Technology Facilities Council (STFC)
Southern African Institute for Nuclear Technology and Sciences (SAINTS)
Technology Innovation Agency (TIA)



Supported 2023-24 under Grant number 14606/01



Thank you for your attention

My email address: shanynhart@tlabs.ac.za

Questions?

Back-up slides

Validation of CC Detector Simulation



Geant 4

TOPAS MC Inc is a proud user of the Geant4 Simulation Toolkit

SrI₂:Eu-SiPM

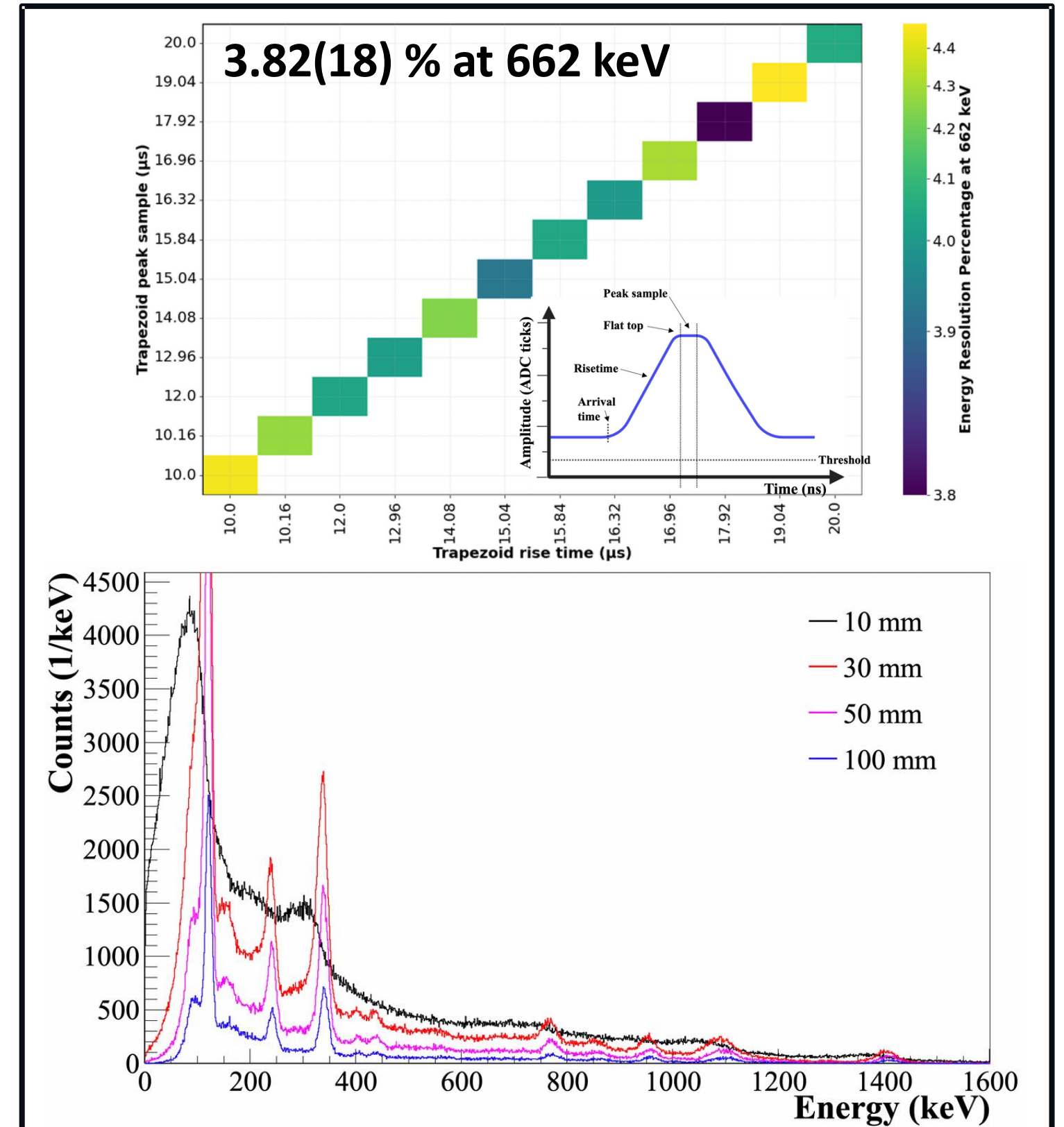
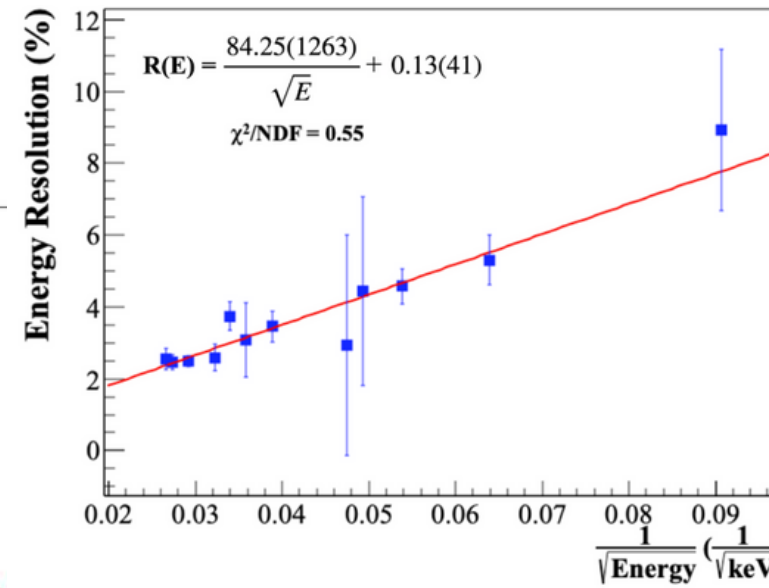
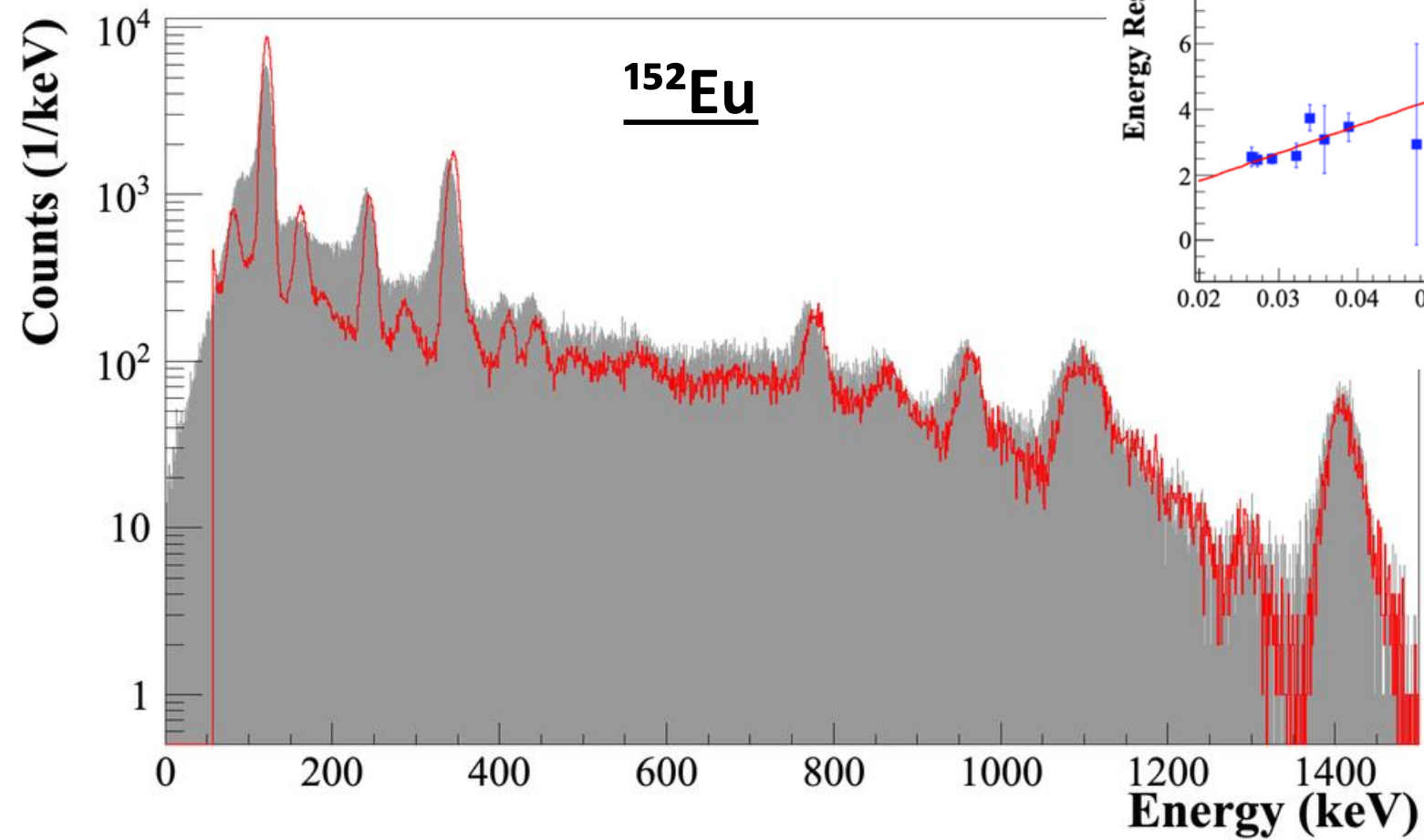

Distance (mm)	344.28 keV			968.08 keV		
	ε _{EXP,FEPE} (%)	ε _{SIMU,FEPE} (%)	Agreement (σ)	ε _{EXP,FEPE} (%)	ε _{SIMU,FEPE} (%)	Agreement (σ)
30.0	0.282(87)	0.480(11)	2.26	0.053(10)	0.043(6)	0.86
50.0	0.124(15)	0.196(9)	4.12	0.031(15)	0.019(3)	0.79
100.0	0.045(6)	0.060(34)	0.43	0.011(3)	0.010(5)	0.17

Table 2: Comparison of experimental and simulation for the SrI₂:Eu DA absolute full-energy peak efficiencies and associated uncertainties for gamma-ray energies 344.28 keV and 968.08 keV at various source-to-detector distances.

Poor agreement, saturation at high count rates

SrI₂:Eu Detector Fast-Timing Resolution



Calculated by gating on the ⁶⁰Co prompt-gamma decays.

The time interval between the 1173 keV and 1332 keV emissions is <0.9 ps, effectively instantaneous compared to detector resolution.

Measurements performed using the PIXIE-16 500 MHz data acquisition system, exploiting the use of the digital CFD for fast timing.

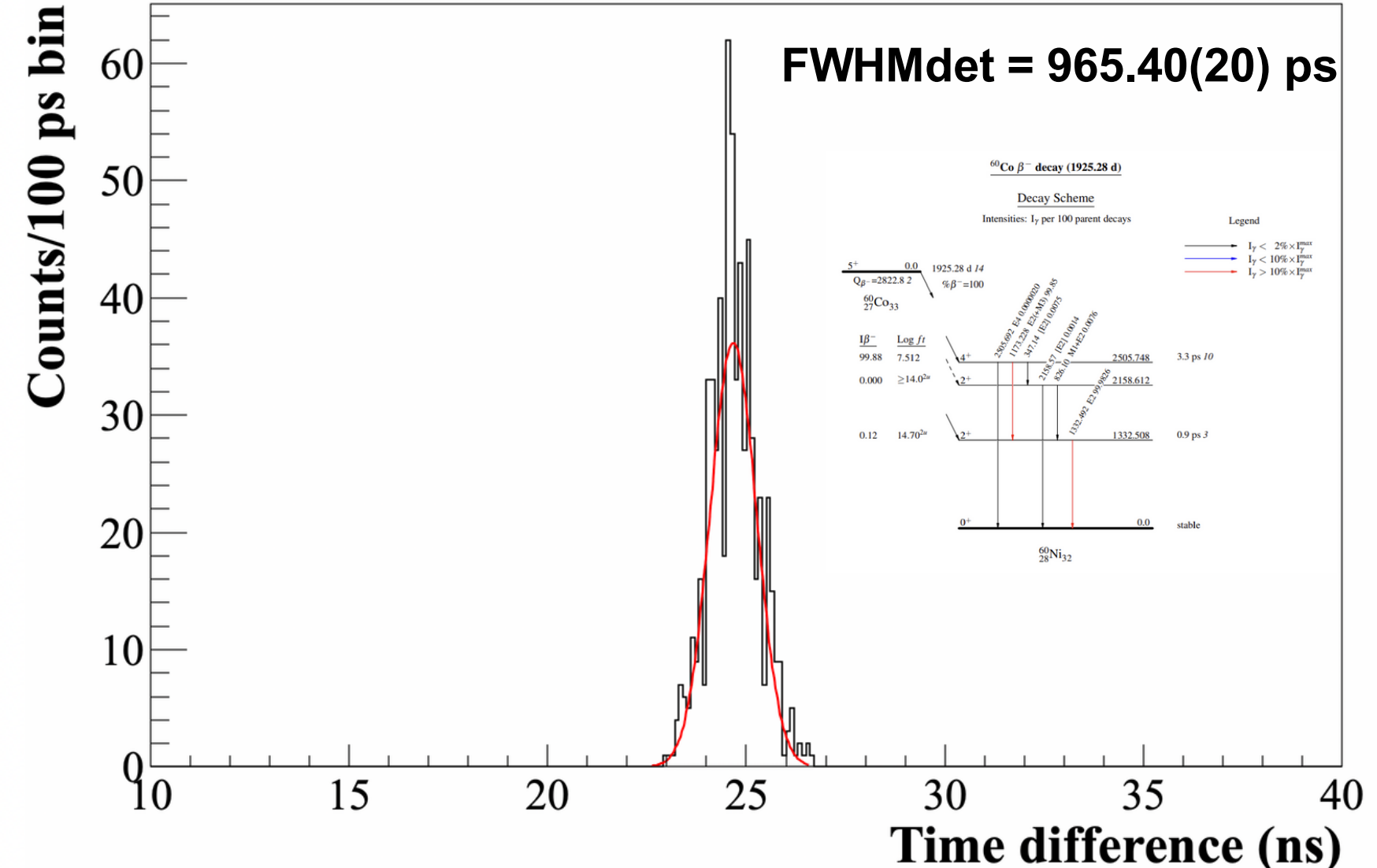
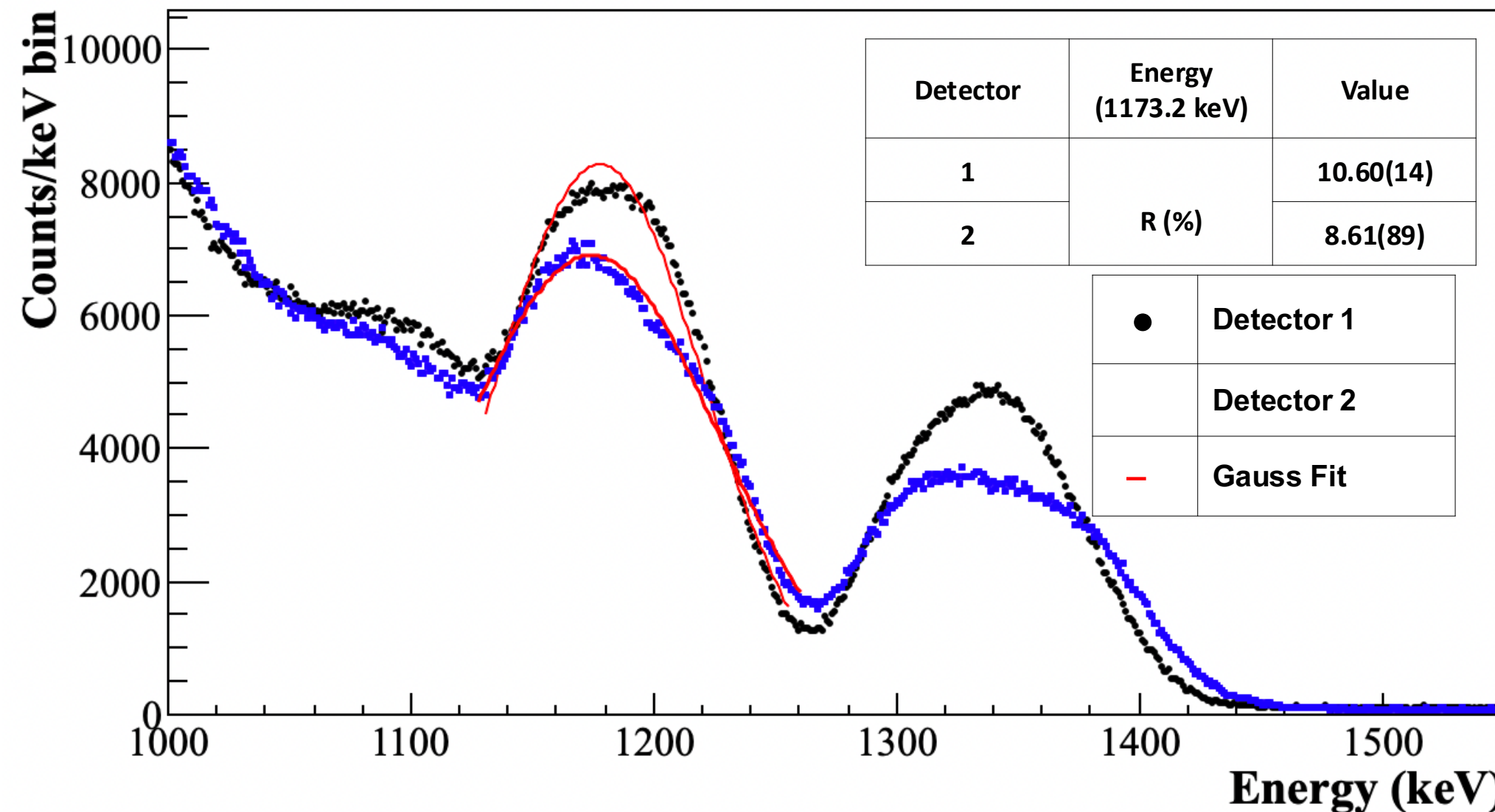

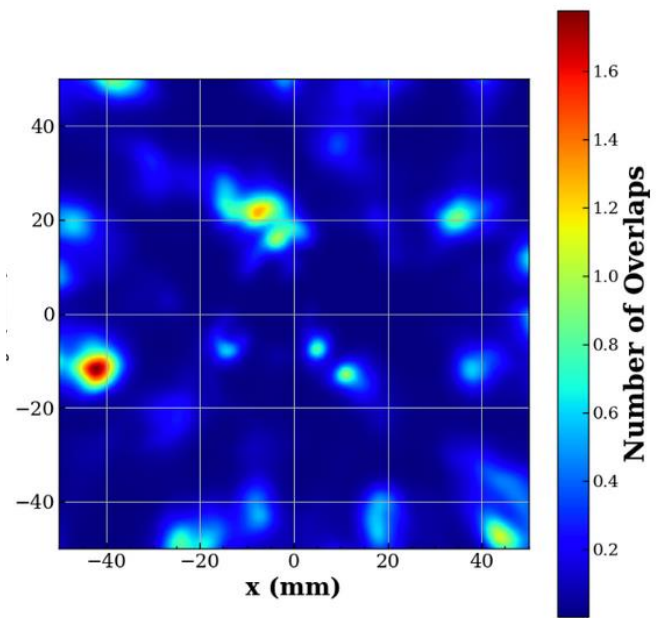

(a)

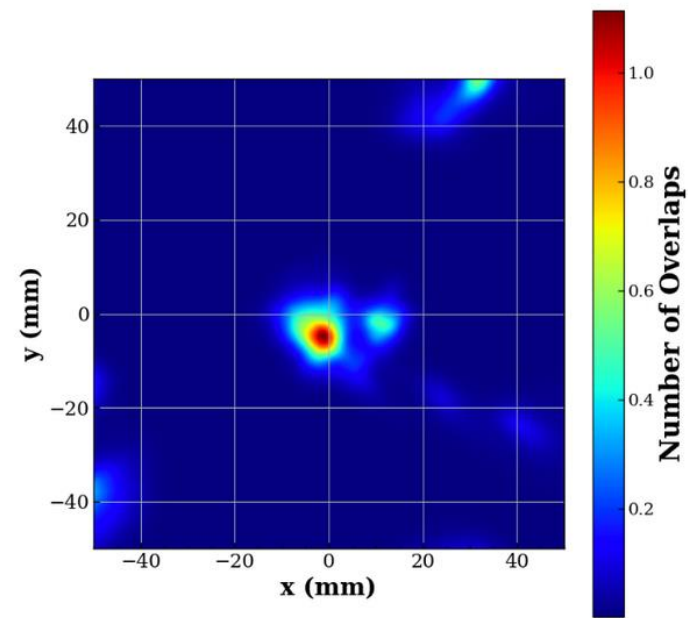

(b)

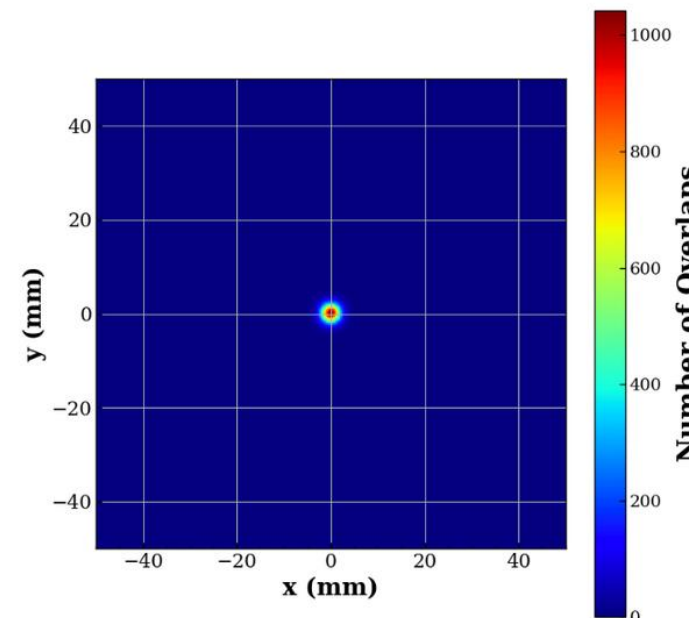

(c)

Image Reconstruction Optimisation

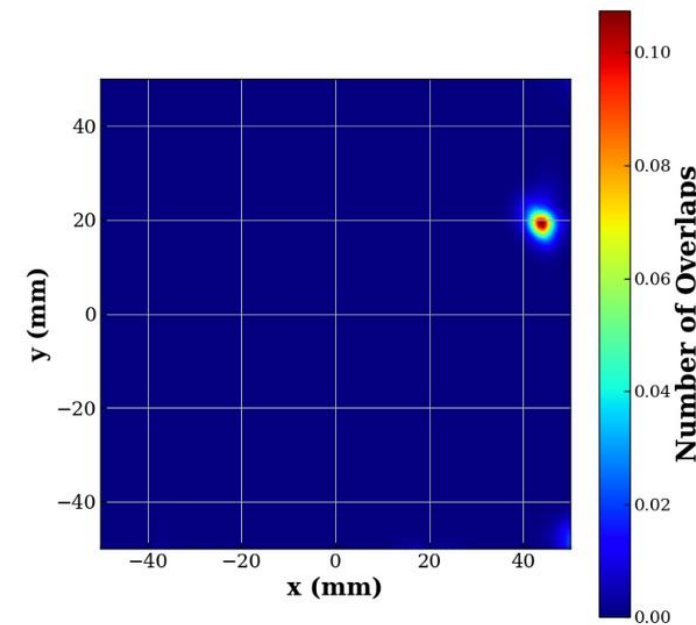
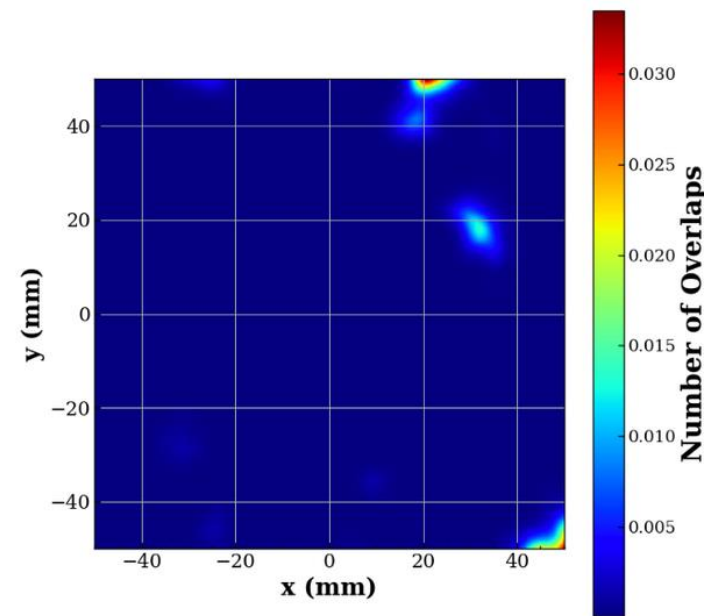

The x-y matrix of CC1 shown at different z slice values for the same Octane EM reconstruction

Image Reconstruction Optimisation

The x and y projections (sliced at the maximum y-z and x-z values respectively) of CC1 shown for different bin width in the Octane EM reconstruction.

5 mm bin width

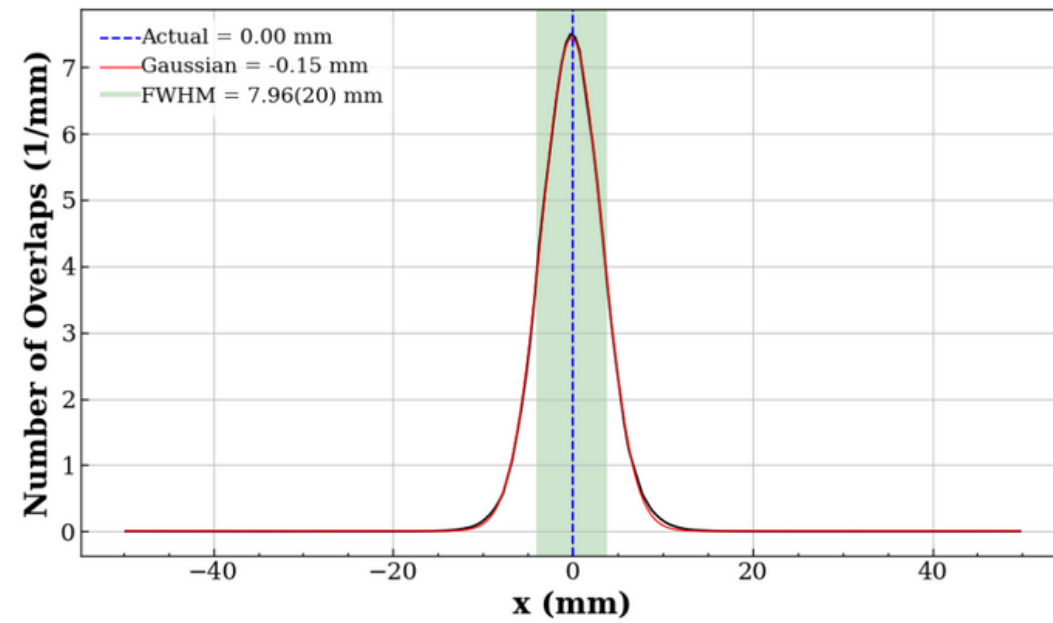

2 mm bin width

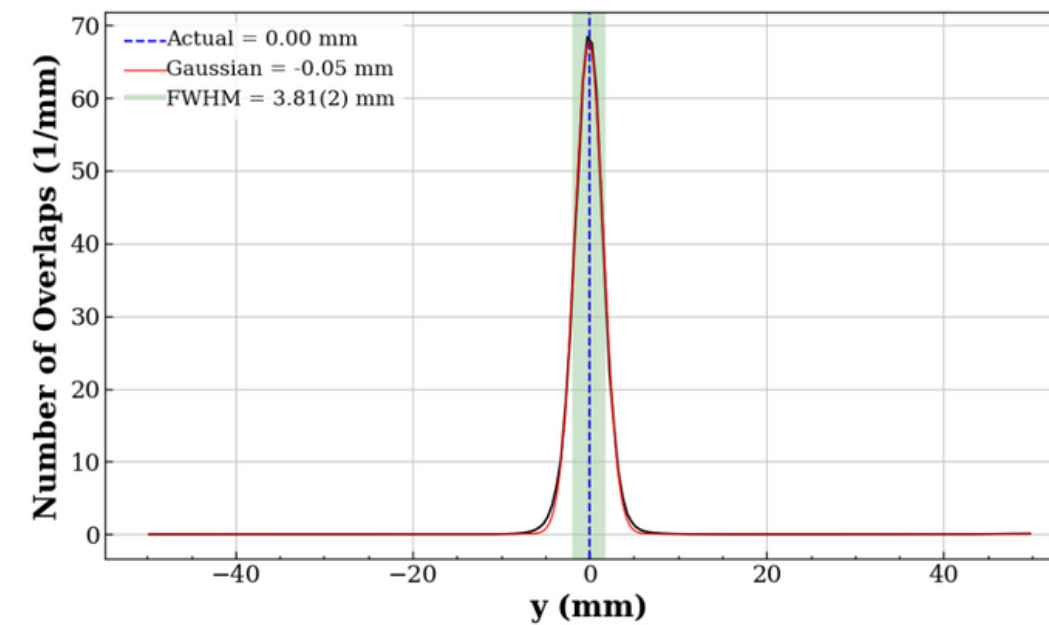
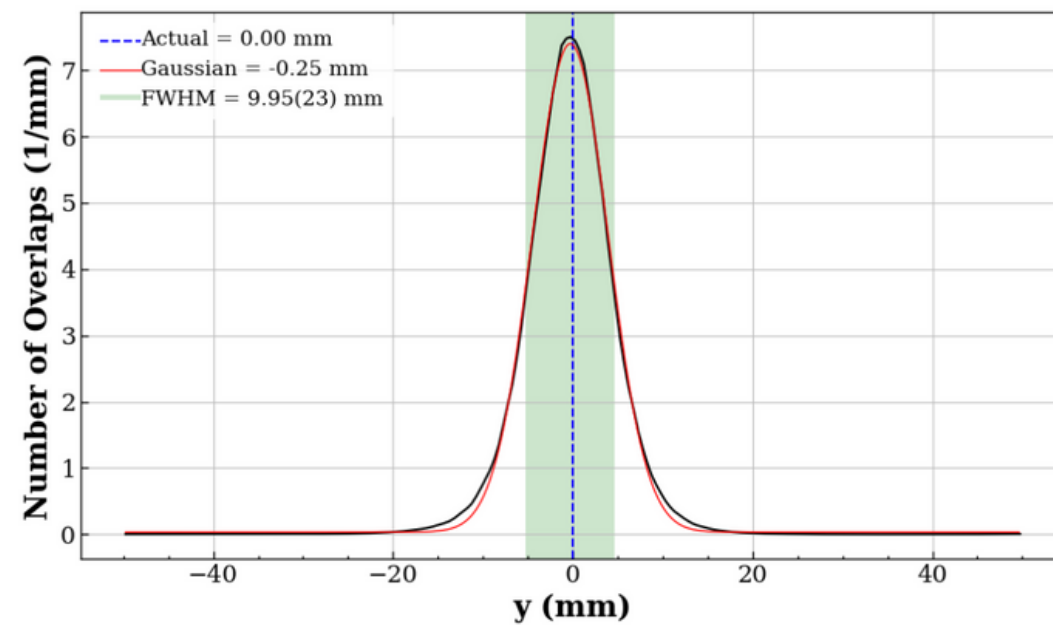
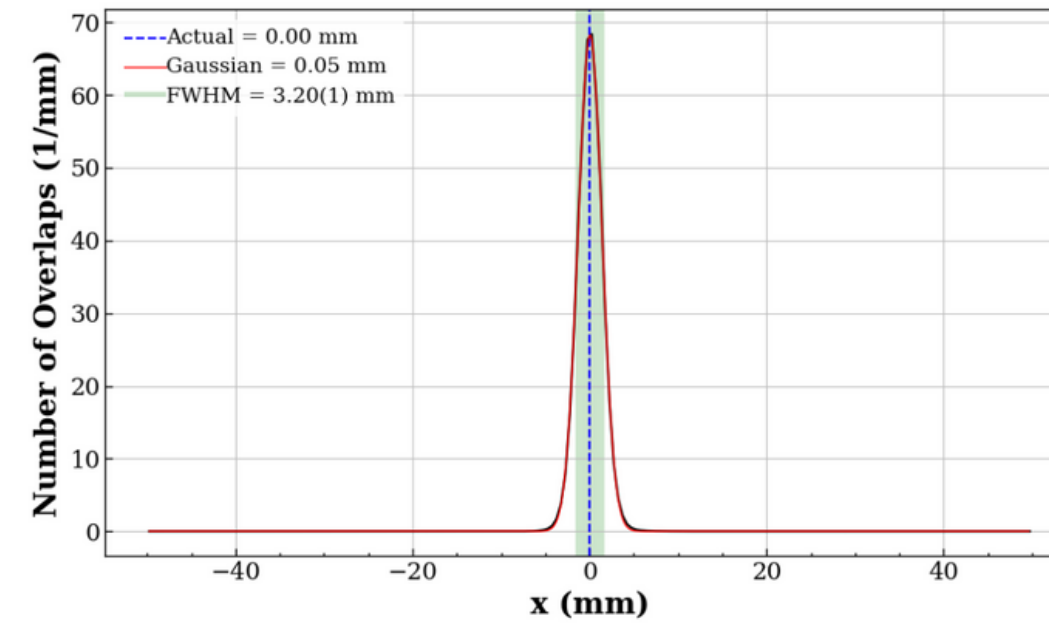

Image Reconstruction Optimisation

The x and y projections (sliced at the maximum y-z and x-z values respectively) of CC1 shown for different numbers of iterations in the Octane EM reconstruction.

